

Wildlife and Train Collision Detection System by Wsn

N.Selvakumar¹, L.P.Sowndharya², M.Swathipriyam³, M.Duraisamy⁴

^{1, 2 & 3} UG Students, Department of ECE, Muthayammal Engineering College, Tamilnadu, India

⁴Assistant Professor, Department of ECE, Muthayammal Engineering College, Tamilnadu, India

Corresponding author: N.Selvakumar

Date of Submission:15-07-2020

Date of Acceptance:31-07-2020

ABSTRACT: The Indian railways are suffering from the collision of animal – rail in forest area. Today, Our India has fourth largest railway network management in the world comes from United states, Russia and China. Considering an India as an example

, in the past five years numerous laws has been passed by the government of India for the protection of wildlife sanctuaries and jungle animals nearby railway track. To overcome this problem, we analyzing the detection of crack and collision of animal – rail in the proximity area. If these deficiencies may result in increasing an Indian railway budget and loss life and property. In this paper proposing cost effectiveness solution to managing this problem of preventing the collision of rail – animal accidents , by utilizing the load cell to receive the accurate location of faulty area in the track and also utilize the load cell to collectively address conservation of animals and living beings by preventing their death being overrun by trains and also monitoring the integrity of the railway track If it is fault which will set right immediately they resulting lead to number of lives can be safe.

KEYWORDS: PIR sensor, LCD, IoT.

I. INTRODUCTION

Wild animals interact with transportation networks in complex ways. Through habitat loss, fragmentation, and degradation as well as direct mortality, the abundance of many species is reduced near roads with potential to alter community composition and ecosystem dynamics. Although the effects of roads on wildlife are typically negative, some species have been found to increase in abundance near roads while others are attracted to the vicinity of roads despite high risk of mortality. Strikes on railways have received less attention, perhaps because they present less risk to people or because railways are less prevalent than roads. Nevertheless, train strikes have been associated with population effects and animals are

sometimes struck more often on railways than on adjacent roads. Additional incentive for strike reduction on railways applies for sensitive or threatened population and charismatic, keystone, or culturally important species. The best method of reducing wildlife-vehicle collision on roads are often impractical on railways. Collision reduction is increasingly achieved through the installation of wildlife exclusion fencing and crossing structures, which can reduce the frequency of wildlife-vehicle collision by up to 80% while maintaining habitat connectivity (reviewed by Glista et al.,2009)

II. EXISTINGSYSTEM

Railways have been the biggest infrastructures of any country and are the most used mode of transportation. The railways have become a new means of transportation owing to their capacity, speed, and reliability. The railways indirectly affect the political, economic and social development in the nineteenth century. Countries like the United States, India, and Canada. The poor maintenance of the railways can lead to accidents. The unavoidable risk associated with derailments and collisions can be reduced by eliminating the root causes. Some of the defects include worn out rails, weld problems, internal defects, corrugations and rolling contact fatigue initiated problems such as surface cracks, headchecks, squats, spilling and shelling.

III. PROPOSEDSYSTEM

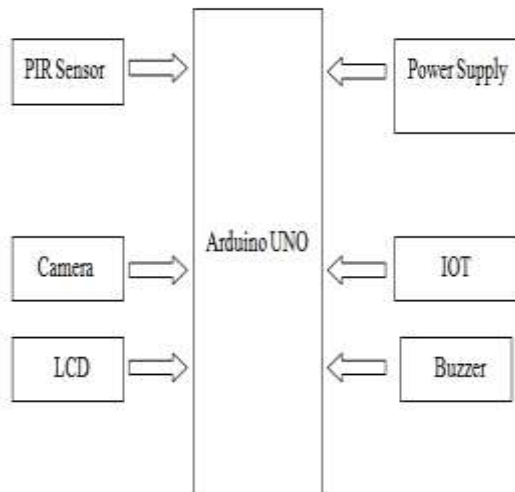

Block diagram of wildlife and train collision detection system

In this proposed method, the preventing animals accident by using PIR sensor and IoT. The heart of the system is Arduino UNO. Once the sensor detects the animal in the rail track. Immediately the information shown on the display and also send the information to specified person through the IoT module. A PIR sensor is a sensor based motion detector is used to sense the movement of the animals, people, and other objects in the rail track. They are commonly used in burglar alarms and automatically- activated lighting systems.

IV. HARDWARE USED ARDUINOUNO:

The Arduino Uno is an open-source microcontroller board based on the Microchip ATmega328P microcontroller and developed by Arduino.cc. The board is equipped with sets of digital and analogue input/output pins that may be interfaced to various expansion boards and other circuits. simply connect it to a computer with a USB cable or power it with a AC-to-DC adapter or battery to get started.



Prototype of Arduino Uno

Arduino function		Arduino function
reset	(PCNT14RESET) PC0	PC3 (ADCSQPCNT3) analog input 3
digital pin 0 (TX)	(PCNT15RD) PC0	PC4 (ADCSQPCNT2) analog input 4
digital pin 1 (TX)	(PCNT17TD) PC1	PC3 (ADCSQPCNT1) analog input 3
digital pin 2	(PCNT18WD) PC0	PC2 (ADCSQPCNT0) analog input 2
digital pin 3 (PWM)	(PCNT19OCBINT1) PC0	PC1 (ADCSQPCNT0) analog input 1
digital pin 4	(PCNT20XCT0) PC4	PC2 (ADCSQPCNT0) analog input 0
VCC	VCC	GND
GND	GND	AREF
crystal	(PCNT8XTAL1TOSC1) PB7	AVCC
crystal	(PCNT7XTAL2TOSC2) PB7	PB6 (ISCRPCNT3) digital pin 13
digital pin 5 (PWM)	(PCNT21OCBINT1) PC0	PB4 (MSQPCNT4) digital pin 12
digital pin 6 (PWM)	(PCNT22OCBINT0) PC0	PB5 (OC3A) digital pin 11 (PWM)
digital pin 7	(PCNT23AN1) PC1	PB2 (ISOCBPCNT2) digital pin 10 (PWM)
digital pin 8	(PCNT0QKICP1) PB0	PB1 (OC1A) digital pin 9 (PWM)

Pin Diagram of Arduino UNO

PIR Sensor:

A passive infrared sensor (PIR sensor) is an electronic sensor that measure infrared (IR) light radiating from objects in its field of view. They are most often used in PIR-based motion detectors.

A PIR-based motion detector is used to sense movement of people, animals, or other objects. They are commonly used in burglar alarms and automatically- activated lighting systems. They are commonly called simply "PIR", or sometimes "PID", for "passive infrared detector".



Prototype of PIR sensor LCD DISPLAY:

LCD is used to display the results of the system operation such as sensed values, motor status etc A liquid-crystal display (LCD) is a flat panel display, electronic visual display, or video display that uses the light modulating properties of liquid crystals. Liquid crystals do not emit light directly. The LCD standard requires 3 control lines and 8 I/O lines for the data bus. The most commonly used Character based LCDs are based on Hitachi's HD44780 controller or other which are compatible with HD44580.

preset time has lapsed, and usually illuminates a light on the appropriate button or control panel, and sounds a warning in the form of a continuous or intermittent buzzing or beeping sound. Initially this device was based on an

electromechanical system which was identical to an electric bell without the metal gong (which makes the ringing noise).



Prototype of Buzzer

V. SYSTEM IMPLEMENTATION



BUZZER:

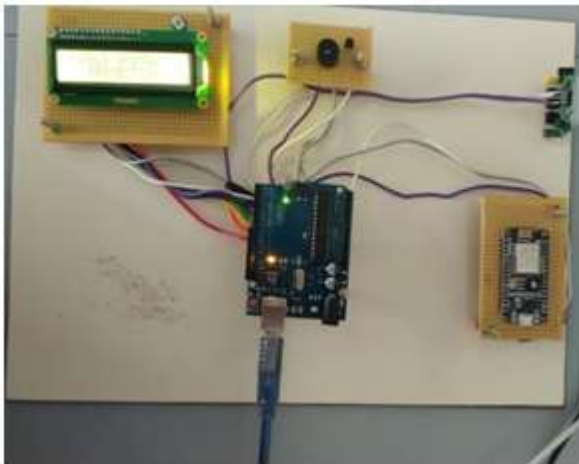

Prototype of LCD Display

Hardware Output of Proposed system

A buzzer or beeper is a signalling device, usually electronic, typically used in automobiles, household appliances such as a microwave oven, or game shows. It most commonly consists of a number of switches or sensors connected to a control unit that determines if and which button was pushed or a

The use of train-triggered warnings for the reduction of wildlife-train strikes makes two assumptions that require further study. First, it assumes the inconsistent availability of train approach

signals increase the risk of animals being struck. Second, it assumes a warning signal will change animal behavior so as to reduce risk of being struck. In recent test of another train-triggered wildlife warning system, animals reacted to trains earlier and were more likely to leave the track when a precisely timed acoustic warning was provided. To determine the success of the system was driven by the temporal consistency of the warning signal, the choice of animal distress calls as warning sounds, or both.

VI. CONCLUSION

Every other day, some or the other species is getting extinct. Some species has become rare. Thousand are endangered. And some are on the verge of extinction. Time have come when strict counter measures needs to be taken up by the Government and made sure that it gets implemented regularly. The automatic tracking and alarm system can eliminate elephant death and injuries due to railway accidents and can also help the forest departments or any other responsible authorities monitor their movement so that they do not stray out of their habitation zone. Not many elephants are left in India. The time is fast approaching when this species will also become endangered. This tracking and alarm system will not be a huge monetary issue for government in terms of implantation and could see a decrement in elephant deaths due to railway accident.

REFERENCES

- [1] AllenWR, Ovulation pregnancy, placentation and husbandry in the African elephant (*Loxodonta Africana*), Philosophical Transactions of the Royal Society of London, SeriesB Biological Sciences(2006).
- [2] Deepak Punetha, Deepak Kumar and Vartika Mehta Design and Realization of the Accelerometer based Transportation System(ATS), in International Journal of Computer Application(2012).
- [3] Robin Des Bois, Information and analysis bulletin on animal poaching and smuggling with the encouragement and financial support of the Foundation Brigitte Bardot, the Ligue pour la Protection des Oiseaux and the Foundation Franz Weber(2015).
- [4] Sha Tao, Vasileios Manolopoulos, Saul Rodriguez, Ana Rusu, Real-time Urban Traffic State Estimation with AGPS Mobile Phones as Probes Journal of transportation technologies(2012).
- [5] Stevenson MF, Walter O, Management guidelines for the welfare of zoo animals:elephants, *Loxodonta African* and

- Elephas maximus. 2nd ed. London: British & Irish Association of Zoos & Aquariums(2006).
- [6] Sukumar.R., The Asian Elephant; Ecology and Management, Cambridge: Cambridge University Press(1989).
- [7] UDOT Wildlife and Domestic Animal Accident Toolkit by Utah Department of transportation Environmental Services & Wildlife & Domestic Animal Accident Quality Improvement Team. Report No. UT 08.07,4501 So 2700 West Salt Lake City, Utah 84114 (2008).

BIOGRAPHY



N.SELVAKUMAR studying her final year B.E degree in Electronics and Communication Engineering from Muthayammal Engineering College, (Autonomous), Anna University, Rasipuram, Tamil Nadu.



L.P.SOWNDHARYA studying her final year B.E degree in Electronics and Communication Engineering from Muthayammal Engineering College, (Autonomous) Anna University, Rasipuram, Tamil Nadu.



M.SWATHIPRIYAM studying his final year B.E degree in Electronics and Communication Engineering from Muthayammal Engineering College, (Autonomous), Anna University, Rasipuram, Tamil Nadu.



M.DURASAMY received his B.E degree in Electronics and Communication Engineering from K.S.R College of Engineering ,Anna University in April 2006 and also received his M.E degree in VLSI Design from Sengunthar Engineering College, Anna

University in June 2012. From August 2009 to June 2010 he was with the Department of Electronics and Communication Engineering as Lecturer in Sengunthar Engineering College, Triuchengode. From July 2012 May 2014 he was with the Department of Electronics and Communication Engineering as Lecturer in Sengunthar Engineering College, Triuchengode. From July 2014 to April 2015 he worked as an Assistant professor in Sri Shanmugha College of Engineering and Technology, Sankari. At present he is working as an Assistant professor in Muthayammal Engineering College, Rasipuram. His current includes low power VLSI Design, Embedded Systems and their applications to wireless communication. He presented and publishes many papers in International and National journals.