

Study on Food waste Management in Narela Railway colony and Station

Manoj Kumar Meena^[1], Mohd Shoeb Alam^[2]

¹Student, Al-Falah University Dhauj, Haryana,

²Assistant Professor, Department Of Civil Engineering, Al-Falah University Dhauj, Haryana,

Submitted: 30-08-2021

Revised: 03-09-2021

Accepted: 05-09-2021

ABSTRACT: There is continuous increase in municipal solid waste (MSW) around the world which has led to extinction of resources and have resulted increase in environmental risks. Conventional treatment methods such as such as open dumping and landfilling causes environmental degradation hence there is need to find better alternative. The major portion of MSW generated in India is organic in nature; Food waste (FW) comprises the main fraction (45%) of this portion. The final destination of FW mainly adopted around the world is Composting or anaerobic digestion. But there are various challenges associated with these methods hence Biofuels derived from the food waste have gained increased interest in recent years due to environmental and economic reasons. The environmental crisis and the depletion of fossil fuel have led the world to look for other alternatives which are renewable in nature and therefore production of biofuels has become an important priority. Also, food waste generation around the globe has become a new environmental concern which has tremendous potential and is not fully unexploited. For this reason, production of ethanol from food waste has become curious approach.

KEYWORDS: Municipal Solid Waste , MSW, Food Waste ,FW, Biofuels, Incineration, Recycling, Narela, Railway colony.

I. INTRODUCTION

The Increase in population, rise in life standard and increase in urbanization have resulted

to a surge in variation of solid waste generated and also increase in quantity. In 2002, the waste generation estimation globally was 1.4 billion tons out of which 1.2 billion tons was industrial and 1.7 billion ton was municipal solid waste (MSW). By 2040, it is estimated that generation of MSW around the globe will be approx. 95 billion (Ajnav et al., 2008). In the same way as other developing nations, India is confronting huge test in dealing with the expanding amount of Municipal Solid waste (MSW) because of its fast population development, change in way of life, relocation of individuals from rural to city zones, and numerous other reasons.

Solid wastes of organic origin include: municipal wastes, agriculture based industrial wastes, horticultural wastes, waste originating from animals, farming wastes and remains. Economic benefits and minimum environmental pollution are the main objective which can be achieved by having effective waste management system. Because of expanding energy demands, budgetary requirements and environmental issues, organization everywhere throughout the world have prescribed different rules and worked on numerous issues related to management of waste.

In Indian cities waste generation rate varies from 0.35 kg/c/d to 0.75 kg/c/d (Yadava and Samader, 2017). Today, MSW generated in India annually is about 60 million tons and it is rising at a quick rate, which is projected to reach around 140 million tons by 2060 (PIB, 2015)

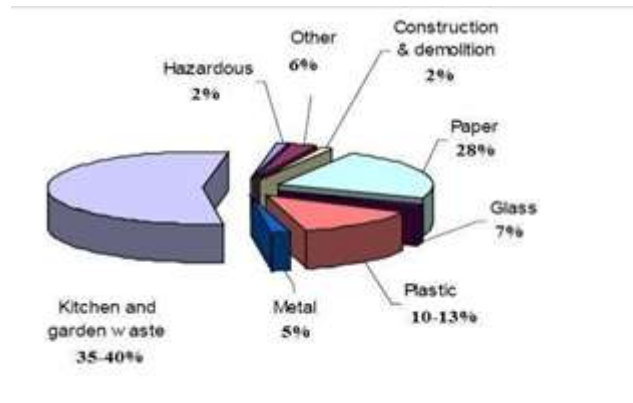

Organic waste is mainly generated from kitchen waste and agriculture wastes. In many developing countries organic waste contribution is increasing day by day. Although, in all these countries a very little percent of the kitchen and garden wastes are used in composting and a major portion goes to dumping sites and forms the most hazardous waste. As kitchen and garden waste is mostly organic, disposal of these wastes through landfilling and combusting results in unwanted situation. The landfilled waste is decomposed by microbes which result in the formation of leachate. This leachate has very serious impact on the environment mainly causing ground water contamination. Organic matter in landfills

additionally frames CH₄ gas and H₂S gas out of which CH₄ is a greenhouse effect causing gas.

Composition of food waste is so much in organic waste hence its potential cannot be ignored and therefore all the countries around the globe should make use this potential. Therefore, in this way there occurs a deliberate requirement to discover effective substitute solutions for treatment of organic wastes especially kitchen waste.

II. METHODOLOGY

The methodology of the study was performed by

- 1- BY Information Collection
- 2- By Survey
- 3- By Analysis of Collected Data

Flow diagram of research methodology -

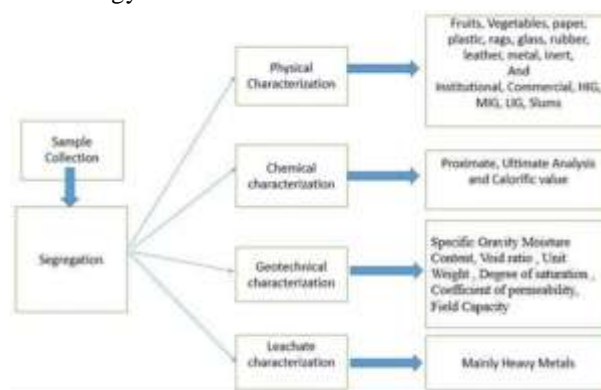

Places	No of person	Amount of food waste Produced (kg)
Houses	450	45.600
Railway Station	5000	105
Canteen		20.80
Other Food waste		18.700

2.1 Chemical Characterization of waste -

“In order to perform characterization of the Chemical characterization of waste has been done to understand its potential for various waste processing techniques, like vermicomposting, composting, refused derived fuel (RDF) and incineration. Proximate analysis involves the determination of, Volatile content (%), % ash content, and the calculation of % fixed carbon. The proximate analysis will be conducted according to ASTM standards E790 (ASTM 2004a), E830 (ASTM 2004b), and E897 (ASTM 2004c). Bomb Calorimeter will be used in order to determine the calorific values.”

The ultimate analysis included determination of carbon, hydrogen, nitrogen, sulphur, and oxygen content in dry samples. The test will be carried out by a CHNS analyser [(Model Vario EL-III) according to the ASTM D3176-09 (ASTM 2002) standard test procedures]. The oxygen content will be determined by difference, knowing the mineral content. Heavy metals will be analysed by using an atomic absorption spectrometer (model 4141, ECI). Prior to the analysis, each sample will be digested with concentrated HNO₃ according to the ASTM standard method D5198-09 (ASTM 2003)

III. EXPERIMENTATION

3.1 Leachate Testing-

Testing of liquid waste (leachate) which generated from Food waste-

Parameter	Actual data	Permissible limit
BOD (mg/l)	12000	30
COD (mg/l)	22000	125
TSS (mg/l)	24500	25
TDS (ppm)	17000	2100
Ph	6	7

3.2 Nutritional Value of Wasted Food & rate of generation-

The food waste that thrown away each day could provide 1217 calories, 33 grams of protein, 5.9 grams of fiber, 1.7 mcg of Vitamin D, 286 mg of Calcium, 880 mg of Potassium to each person

3.3 Amount of food waste produced daily –

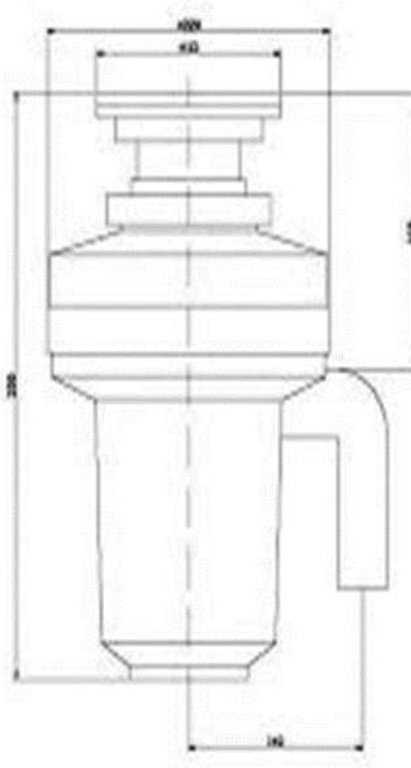

IV. RESULT AND DISCUSSION

Design of food waste disposal system – Disposer drum

Main components,

1. Hopper
2. Disposer drum
3. Masher blade
4. Motor

Arrangement of various components of the disposer system are as follows:

Supporting frame is selected which holds the total assembly together.

Sink/hopper is mounted on the frame whereas on other side motor is vertically fitted inside the casing.

Output shaft of the motor is connected to the masher blades which mash the waste food in fine particles.

Crushed waste sustenance is diverted through the outlet pipe provides just below the masher blades.

Disposed waste is collected in the bucket provided below the outlet pipe.

Screws and fasteners are used to hold the assembly together and to prevent the any leakages

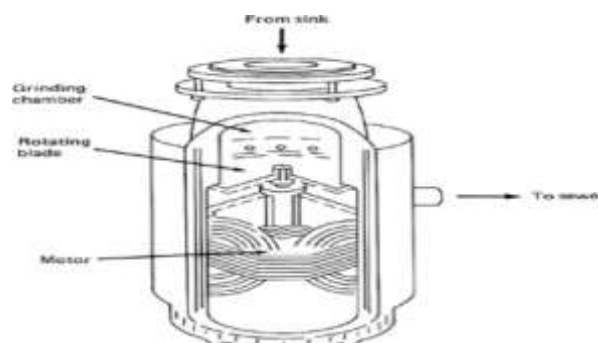

Volume $V = 3.14 r^2 l$

V = volume of drum

r = inner radius of drum l = length of drum

4.1 Design Description

The transfer framework comprises of a drum produced using tempered steel, and is encased by an external barrel mounted straightforwardly on an edge. A sink structure enters from outside through the round and hollow fenced in area into the drum. A 19mm diameter shaft pass through the center of the disposal drum vertically and spans through the one third of the length of disposal drum inside, on which a masher is mounted & is being driven by a 0.5HP motor with an average output speed of 2300rpm. The masher does the undertaking of squashing the waste materials against the inward of the transfer chamber

4.2 Testing of compost produced from Food waste

Collection of compost

Compost was collected from waste treatment plant. A quantity of 2 Kg of compost wastaken from waste treatment plant for physico-chemical analysis. Four compost sampleswere made of 500 gm each.

Preparation of Test Sample

The composite sample acquired from the waste treatment plant was spreade out on a clean and plane surface then it was distributed approximately

in three equal shares. Each of these samples shall constitute the test sample.

Physio-chemical Analysis

Bulk Density

Apparatus

Weighing balance, measuring cylinder (100 ml), Rubber pad (0.093 m²; 2.57 cm thickness), Hot air oven

Procedure

Compost sample was dried in a hot air oven at 70° C for 24 hours and a 100 ml cylinder was weighed. After weighing the cylinder it was filled with the sample up to the 100 ml mark and again it was weighed with the sample. Cylinder was tapped for two minutes for compacting the sample. And finally the compact volume was measured.

Calculation

$$\text{Bulk density (g/cm}^3\text{)} = \frac{W_2 - W_1}{V}$$

Where,

W_1 = Weight of the dry 100 ml cylinder in g

W_2 = Weight of the dry 100 ml cylinder with sample in g

V = Final volume up to which the sample is present in the cylinder after compaction in ml



Measuring cylinder and weighing balance used in bulk density estimation of compost sample

Moisture content

Apparatus

Petri dish, Hot air oven, desiccator, weighing _____

Balance Procedure

Prepared sample measuring 10 g was taken in a clean petri dish. After that prepared sample was heated at 70°C for 24 hours in the oven till weight

becomes constant. It was then cooled in the desiccator and weighed again.

Calculation

Moisture percent by mass =

Where,

A = Mass of the petri dish

B = Mass of the petri dish with sample before drying; and C = Mass of the petri dish with sample

after drying

Desiccators and Oven used for moisture content estimation of compost sample



pH

Reagent

Buffer solution, distilled water Apparatus

Rotary shaker, Whatman filter paper, pH meter.

Procedure

A suspension was made in 50 ml distilled water by mixing of 25 g of compost in it and the suspension was shaken on a rotary shaker for 2 hours. After that suspension was filtered through Whatman filter paper using a funnel. Finally pH of the filtered sample was determined using pH meter.



Experimental setup to determine pH of compost sample

Conductivity

Apparatus

Conductivity meter, 4 mm sieve, flask (250 ml), funnel, beaker (100 ml), analytical balance, filter paper.

Procedure

Electrical conductivity of compost sample was determined by the means of conductivity meter (Aquapro). A fresh sample was first passed through a . 4 mm sieve and then 2.0 g of the sample was taken and 10.0 ml of distilled water was added to it to give a ratio 1:5. The conductivity meter was first washed with distilled water and after that reading was taken. At last reading was taken by inserting the conductivity meter in the sample till reading gets stabilized.



Conductivity meter used for determination of conductivity of compost sample

4.4 Chemical Characterization

Parameter	Unit	Value
Moisture Content	% by Weight	20.2
Volatile Matter	% by Weight	21.3
Ash Content	% by Weight	47.2
Fixed Carbon	% by Weight	11.3
Calorific Value	KJ/ Kg	4,387

Carbon	% by Weight	25.2
Hydrogen	% by Weight	3.87
Nitrogen	% by Weight	1.34
Oxygen	% by Weight	20.9
Mineral Content	% by Weight	48.69

4.5 Physio-chemical results of produced compost-

In this section the compost which is produced in waste treatment plant from food waste was tested and following parameters such as bulk density, moisture content, pH, electrical conductivity and C/N ratio were determined, The standard methods used to determine these parameters are discussed

Parameter	Value
Bulk density	0.549 g/ cubic cm
Moisture content	4.72 %
pH	5.80
Conductivity	3.1 Ds m-1
C/N ratio	32:14.6

Physio-chemical characteristic of compost –



In this section the compost which is produced in waste treatment plant from food waste was tested and following parameters such as bulk density, moisture content, pH, electrical

conductivity and C/N ratio were determined . The standard methods used to determine these parameters are discussed in previous chapter. The observation are given in table 4.1

Physio-chemical characteristics of compost

Parameter	Value
Bulk density	0.549 g/cm ³
Moisture content	3.72
pH	3.80

Conductivity	3.1 dsm ⁻¹
C/N ratio	32:1

V. CONCLUSIONS

In this chapter findings of thesis have been discussed which gives significant findings in the management of food waste. In this Present study shortcoming in the present FW management system were studied and efforts were made to explore the alternate management method for food waste.

Findings from the current management system showed that there is no proper source segregation of waste and Food Waste is disposed of commonly with other waste produced. As the Food Waste has great potential it can be explored separately to other treatment option like ethanol and biofuel production as food waste is immediate source of starch and sugar. The Physico-chemical characteristics of conventional compost were also determined. Moisture content and pH obtained for the conventional compost were 3.72 % and 3.80 respectively which is less than the prescribed limit.

As if now composing RDF, biomethanation and disposal of rejects and inerts seems to be suitable waste processing technology. Organic fraction has been significant so composting should be appropriate method to process the waste.

Explosive increment in the waste

generation and scarcity of land to manage the waste will require best strategies for the waste management in the coming time. Although public participation is also very important, and will remain a great challenge in front of the local administration. There is a need of efficient planning by the collaboration of local administration and private sector which will improve the aesthetic and hygiene level in the city and also spread awareness among the people not to spread trash on the roadsides and to cooperate in this mission in mission in their best interest.

There are certain ways through which operating cost of the waste management system can be reduced.

- 1- If proper segregation of waste is done at the source then labour cost can be reduced as the number of labour employed for the segregation activity can be reduced.
- 2- In many European countries insinkerator disposerer are used for grinding food waste at the source itself. Hence it can also be employed



VI. FUTURE SCOPE OF WORK

The present study was mainly focused to study the current food waste management system. Food Waste has great potential as individual fraction of organic waste and alternate disposal

option i.e. Bio Fertilizer, Ethanol & Biogas production from Food Waste. The following future work could be taken up based on the present work:

- Detailed study on proper collection system of Food Waste is needed.

- Study of other conventional treatment option for Food Waste is needed.

REFERENCE

- [1]. Adhikari, Bijaya K., Suzelle Barrington, Jose Martinez, and Susan King. "Characterization of food waste and bulking agents for composting." *Waste Management* 28, no. 5 (2008): 795-804.
- [2]. Ajnavi S. "Bioconversion of cellulosic agricultural wastes", a dissertation of masters of technology, Department of Biotechnology and Environmental Sciences, Thapar University, (2008).
- [3]. Akpan, Uduak George, Adamu Ali AL hakim, and Udemé Joshua Josiah Ijah. "Production of ethanol fuel from organic and food wastes." *Leonardo Electronic Journal of Practices and Technologies* 13 (2008): 1-11.
- [4]. ASME, American Society of Mechanical Engineers, 2005. *Waste-to-Energy: A Renewable Energy Source from Municipal Solid Waste*.
- [5]. Asnani, Peter U. "Solid waste management." *India infrastructure report* 570 (2006).
- [6]. Baadger, P. C. "Ethanol from cellulose: a general review." *Trends in new crops and new uses* 1 (2002): 17-21.
- [7]. Bockris, JOM. "The origin of ideas on a hydrogen economy and its solution to the decay of the environment." *International journal of hydrogen energy* 27, no. 7-8 (2002): 731-740.
- [8]. Cara, Cristóbal, Encarnación Ruiz, José Miguel Oliva, Felicia Sáez, and Eulogio Castro. "Conversion of olive tree biomass into fermentable sugars by dilute acid pretreatment and enzymatic saccharification." *Bioresource technology* 99, no. 6 (2008): 1869-1876.
- [9]. Center for Climate and Energy Solutions, 2017. *Main Greenhouse gases*.
- [10]. Cerda, Alejandra, Adriana Artola, Xavier Font, Raquel Barrena, Teresa Gea, and Antoni Sánchez. "Composting of food wastes: Status and challenges." *Bioresource technology* (2017).
- [11]. Colón, Joan, Erasmo Cadena, Michele Pognani, Raquel Barrena, Antoni Sánchez, Xavier Font, and Adriana Artola. "Determination of the energy and environmental burdens associated with the biological treatment of source-separated municipal solid wastes." *Energy & Environmental Science* 5, no. 2 (2012): 5731-5741.
- [12]. Dawson, Letha, and Raj Boopathy. "Use of post-harvest sugarcane residue for ethanol production." *Bioresource technology* 98, no. 9 (2007): 1695-1699.
- [13]. Dekker, ROBERT FH. "Steam explosion: an effective pretreatment method for use in the bioconversion of lignocellulosic materials." *Steam Explosion Techniques. Fundamentals and Industrial Applications* (1991): 277-305.
- [14]. Dhar, Hiya, Sunil Kumar, and Rakesh Kumar. "A review on organic waste to energy systems in India." *Bioresource technology* 245 (2017): 1229-1237.
- [15]. Dresselhaus, M. S., and I. L. Thomas. "Alternative energy technologies." *Nature* 414, no. 6861 (2001): 332.
- [16]. Duff, Sheldon JB, and William D. Murray. "Bioconversion of forest products industry waste cellulose to fuel ethanol: a review." *Bioresource technology* 55, no. 1 (1996): 1-33.
- [17]. Dulac, N. "Tools for decision makers: experiences from the Urban Waste Expertise Programme (1995-2001): The organic waste flow in integrated sustainable waste management." *WASTE*, 2001.
- [18]. Dutta, M. (1997). *Waste disposal in engineered landfills*. Narosa Publishing House, New Delhi
- [19]. Dwivedi, Puneet, Janaki RR Alavalapati, and Pankaj Lal. "Cellulosic ethanol production in the United States: Conversion technologies, current production status, economics, and emerging developments." *Energy for Sustainable Development* 13, no. 3 (2009): 174-182.
- [20]. Erdei, Borbala. *Development of integrated cellulose-and starch-based ethanol production and process design for improved xylose conversion*. Department of Chemical Engineering, Lund University, 2013.
- [21]. Gilbert, E. J., A. Kelsey, J. D. Karnon, J. R. M. Swan, and B. S. Crook. "Preliminary results of monitoring the release of bioaerosols from composting facilities in the UK: interpretation modelling and appraisal of mitigation measures." In *Proceedings of the International Symposium Composting and Compost Utilization*, pp. 1094-1105. 2002.
- [22]. Grohmann, Karel. "Simultaneous saccharification and fermentation of cellulosic substrate to ethanol." *Biotechnol. in Agric.* 9 (1993): 183-209.

- [23]. Grous, William R., Alvin O. Converse, and Hans E. Grethlein. "Effect of steam explosion pretreatment on pore size and enzymatic hydrolysis of poplar." *Enzyme and Microbial Technology* 8, no. 5 (1986): 274-280.
- [24]. Gue, Rui, Guoxue Li, Tao Jiang, Frank Schuchardt, Tongbin Chen, Yuanqiu Zhao, and Yujun Shen. "Effect of aeration rate, C/N ratio and moisture content on the stability and maturity of compost." *Bioresource Technology* 112 (2012): 171-178.
- [25]. Gupta, Shuchi, Krishna Mohan, Rajkumar Prasad, Sujata Gupta, and Arun Kansal. "Solid waste management in India: options and opportunities." *Resources, conservation and recycling* 24, no. 2 (1998): 137-154.
- [26]. Halim, Cheryl E., Jason A. Scott, Rose Amal, Stephen A. Short, Donia Beydoun, Gary Low, and Julie Cattle. "Evaluating the applicability of regulatory leaching tests for assessing the hazards of Pb-contaminated soils." *Journal of hazardous materials* 120, no. 1-3 (2005): 101-111.
- [27]. Harrison, J.S., 1963. *Baker's Yeast*, Chapter 2, *Biochemistry of Industrial Microorganisms*, Academic Press, London.
- [28]. Haug, R.T., 1993. *The Practical Handbook of Compost Engineering*. Lewis Publishers, Boca Raton.
- [29]. Hoornweg, Daniel, and Laura Thomas. *What a waste: solid waste management in Asia*. The World Bank, 1999.
- [30]. Intergovernmental Panel on Climate Change, 2012. *Renewable Energy Sources and Climate Change*.
- [31]. IPCC, 2007. *Fourth Assessment Report. Complete Report*, Intergovernmental Panel on Climate Change, Cambridge, University Press.
- [32]. Jhaa, Arvind K., C. Sharma, Nahar Singh, R. Ramesh, R. Purvaja, and Prabhat K. Gupta. "Greenhouse gas emissions from municipal solid waste management in Indian megacities: A case study of Chennai landfill sites." *Chemosphere* 71, no. 4 (2008): 750-758.
- [33]. Joelsson, Elisabeth. *Techno-economic evaluation of integrated lignocellulosic ethanol production*. Department of Chemical Engineering, Lund University, 2015.
- [34]. Jones, Alison M., Kolothumannil C. Thomas, and W. Michael Ingledew. "Ethanol fermentation of blackstrap molasses and sugarcane juice using very high gravity technology." *Journal of agricultural and food chemistry* 42, no. 5 (1994): 1242-1246.
- [35]. Karmee, Sanjib Kumar. "Liquid biofuels from food waste: current trends, prospect and limitation." *Renewable and Sustainable Energy Reviews* 53 (2016): 945-953.
- [36]. Kim, Sehoon, and Mark T. Holtzaple. "Lime pretreatment and enzymatic hydrolysis of corn stover." *Bioresource technology* 96, no. 18 (2005): 1994-2006.
- [37]. Komilis, Dimitris P., Robert K. Ham, and Jae K. Park. "Emission of volatile organic compounds during composting of municipal solid wastes." *Water research* 38, no. 7 (2004): 1707-1714.
- [38]. Kumar, Atul, and S. R. Samadder. "An empirical model for prediction of household solid waste generation rate—A case study of Dhanbad, India." *Waste Management* 68 (2017): 3-15.
- [39]. La, Aiduan, Blanca Antizar-Ladislao, and Majeda Khraisheh. "Bioconversion of municipal solid waste to glucose for bioethanol production." *Bioprocess and Biosystems Engineering* 30, no. 3 (2007): 189-196.
- [40]. Lalue, Cecília, C. L. Abud, W. Greenhalf, and Peres MF Sanches. "Thermotolerance behavior in sugar cane syrup fermentations of wild type yeast strains selected under pressures of temperature, high sugar and added ethanol." *Biotechnology letters* 15, no. 6 (1993): 609-614.
- [41]. LaRivier, M., 2007. *Energy Information Administration (EIA), Trends in Municipal Solid Waste (MSW) Composition*, Department of Energy.
- [42]. Le, Zhentong, Hongwei Lu, Lixia Ren, and Li He. "Experimental and modeling approaches for food waste composting: A review." *Chemosphere* 93, no. 7 (2013): 1247-1257.
- [43]. Lundie, Sven, and Gregory M. Peters. "Life cycle assessment of food waste management options." *Journal of Cleaner Production* 13, no. 3 (2005): 275-286.
- [44]. Magyar, Margaret, Leonardo da Costa Sousa, Singaram Jayanthi, and Venkatesh Balan. "Pie waste—A component of food waste and a renewable substrate for producing ethanol." *Waste Management* 62 (2017): 247-254.

- [45]. Makan, Abdelhadi, Omar Assobhei, and Mohammed Mountadar. "Effect of initial moisture content on the in-vessel composting under air pressure of organic fraction of municipal solid waste in Morocco." *Iranian journal of environmental health science & engineering* 10, no. 1 (2013): 3.
- [46]. Mani, Sudhagar, Lope G. Tabil, and A. Opoku. "Ethanol from agricultural crop residues-An overview." *The Society for engineering in Agriculture, food and biological systems*. Paper No: MBSK (2002): 02-217.
- [47]. Moulijn, Jacob A., Michiel Makkee, and Annelies E. Van Diepen. *Chemical process technology*. John Wiley & Sons, 2013.
- [48]. Nakasaki, Kiyohiko, and Hidehira Hirai. "Temperature control strategy to enhance the activity of yeast inoculated into compost raw material for accelerated composting." *Waste Management* 65 (2017): 29-36.
- [49]. Narendranath, Neelakantam V., Kolothumannil C. Thomas, and W. Michael Ingledew. "Acetic acid and lactic acid inhibition of growth of *Saccharomyces cerevisiae* by different mechanisms." *Journal of the American Society of Brewing Chemists* 59, no. 4 (2001): 187-194.
- [50]. Nixon, J. D., P. K. Dey, and S. K. Ghosh. "Energy recovery from waste in India: An evidence-based analysis." *Sustainable Energy Technologies and Assessments* 21 (2017): 23-32.
- [51]. OECD, 2002, Organization for Economic Co-operation and Development, Sustainability Statistics, [www.document]http://maps.grida.no/go/graphic/municipal_solid_waste_composition_for_7_oecd_countries_and_7_asian_cities.