

## Smart Agriculture System Using Raspberry Pi

Ms.R.DEIVANAI, M.E.,(Ph.D).

D.Archana, G.Gayathri, G.Joychristy, P.Nivetha.

*Vivekanandha College of Technology for Women  
Electrical And Electronics Engineering Department*

Date of Submission: 16-06-2020

Date of Acceptance: 02-07-2020

### ABSTRACT

In olden Days Farmers used to figure the ripeness of soil and influenced suspicions to develop which to kind of yield. They didn't think about the humidity, level of water and especially climate condition which terrible a farmer increasingly The Internet of things (IOT) is remodeling the agribusiness empowering the agriculturists through the extensive range of strategies, for example, accuracy as well as practical farming to deal with challenges in the field. IOT modernization helps in assembly information on circumstances like climate, dampness, temperature and fruitfulness of soil, Crop web based examination empowers discovery of wild plant, level of water, bug location, creature interruption in to the field, trim development, horticulture. IOT utilize farmers to get related with his residence from wherever and at whatever point. Remote sensor structures are utilized for watching the homestead conditions and tinier scale controllers are utilized to control and mechanize the home shapes. To see remotely the conditions as picture and video, remote cameras have been used. IOT development can diminish the cost and update the productivity of standard developing.

**KEYWORDS:** Soil moisture sensor, Water level sensor, Humidity sensor, Temperature sensor, Raspberry pi.

### I. INTRODUCTION:

The Agriculture Parameters are utilizing an IOT Technology and system availability that draw in these objects to assemble and deal information. "The IOT enables things selected recognized or potentially forced remotely crosswise over completed the process of existing

configuration, manufacture open gateways for all the additional obvious merge of the substantial earth into PC based frameworks, in addition to acknowledging overhauled capacity, precision and cash interconnected favoured stance. Precisely when IOT is extended with sensors and actuators, the improvement modify into an occasion of the all the extra wide category of electronic physical structures, which in like manner incorporates headways, for instance, clever grids, splendid homes, canny moving and smart urban groups [1]. All is especially specific through its introduced figuring configuration anyway can interoperate within the current Internet establishment.

### II. LITERATURE SURVEY

Ayush Kumar and at al utilized IoT and picture handling to locate the supplement and mineral insufficiencies that influence the yield development [1].M.K. Gayathri and at al advance the quick improvement of agrarian modernization and help to acknowledge brilliant answer for horticulture and productively explain the issues identified with ranchers [2]. Zhou Zhongwei and at al have proposed a technique to picture and follow rural items in inventory network [3]. Li Sanbo and at al centre around the equipment engineering, arrange design and programming process control of the exactness water system framework [4].Smash and atal have proposed an approach to direct water in rural fields [5]. Bo Yifan and atal have concentrated on the investigation on the use of distributed computing and the web of things in horticulture and ranger service [6]. M.V. Latte and at al have utilized shading and example investigation to recognize numerous insufficiencies in paddy leaf pictures.

### III. BLOCK DIAGRAM

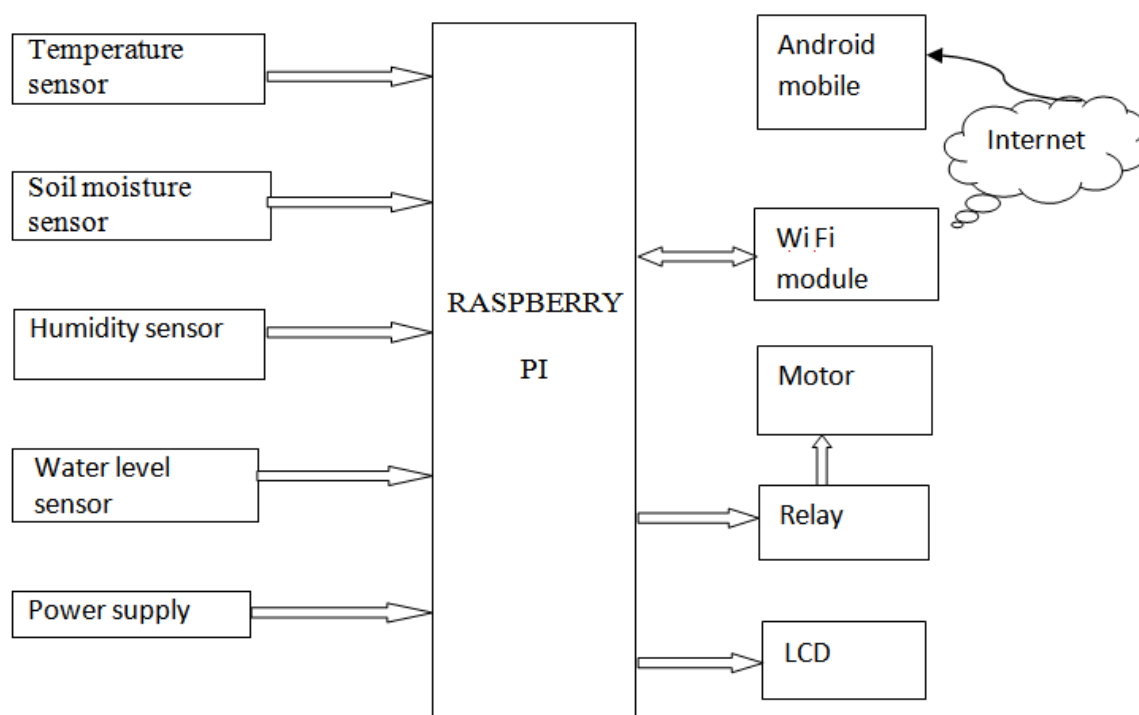

Fig: Block diagram of smart agricultural system

### IV. METHODOLOGY

The reason for the Raspberry pi controller is that it interfaces every one of the parts related with the Development pack. Number of pins in this processor is 64. Each stick is relegated with specific segment of the unit for performing specific capacity. The edge estimation of the sensors is set in this LPC 2148 processor which is in charge of the programmed ON and OFF of the engine which is combined with the pump for directing water to the horticultural land. The temperature limit esteem will be refreshed to server or framework, through IoT for each 1 minute from the incorporated advancement pack. LM35 temperature sensors utilize speaker at the accurate supporters outright temperature (estimated in Kelvin) into also Fahrenheit or Celsius rely leading it arrangements. The two resistors are adjusted in the production line to create an exceedingly exact temperature sensor. The coordinated START Read the information Deployment of Sensor Is Temperature/the Humidity esteems in go Is the water esteems in run Motor on STOP NO YES Data server (IoT passage) circuit has various transistors in it - two in the centre, a few in each intensifier, a few in the dependable flow source, and several in the bend give circuit. The edge esteem is achieved (1 RH%-100 RH%) this breaking points can be set in the

microcontroller if its goes above past 10 RH% conditions will be unusual generally dampness level will be in ordinary conditions. The qualities can have refreshed to framework through IoT passage [6]. The highlights of stickiness sensor are excellent linearity, low power utilization, wide estimation extend, fast reaction, against contamination, high dependability, elite value proportion. Water level pointer is utilized to quantify the water level in water system arrive. In the water level sensor esteem measure by utilizing scale level and it's speak to in cm. On the off chance that the water level achieves the base of the metal bar it demonstrates unusual condition and the control will consequently turn ON, the engine. In the event that the water achieves the specific level the engine can be killing naturally. These statuses can be endlessly revived to the structure using IoT. The Internet of things (IOT) would be the internetworking [8] connected with brute machinery, transit, architecture and varying things embedded with equipment, programming, sensors, actuators, and framework organize that engage these articles to gather and exchange data. These contraptions hoard critical data with the help of various existing advances and after that uninhibitedly stream the data between various devices.

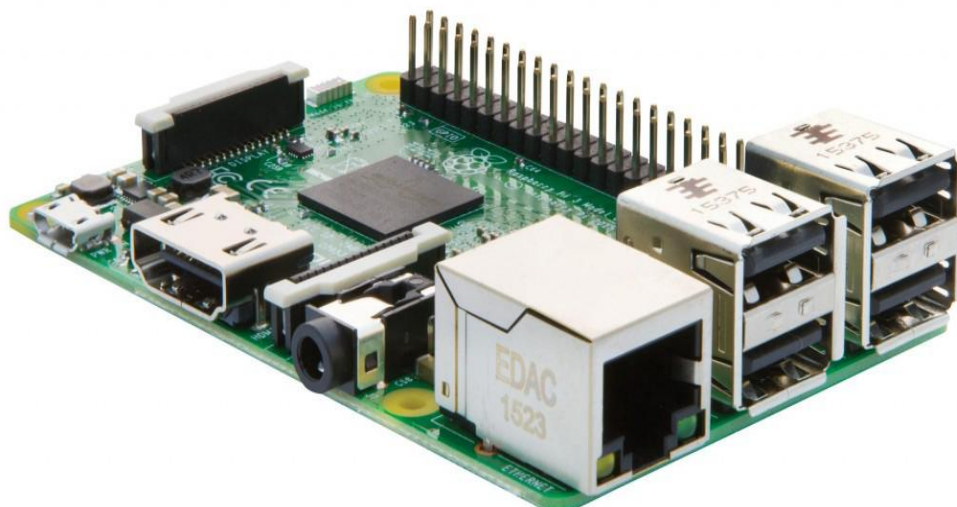

Fig: Raspberry pi board

## V. RESULT

The yield appeared beneath signifies the temperature, soil dampness state and the gate crasher discovery. The next outcome is the yield as of the Android purpose that is produced in the cell phone. It decides the temperature, stickiness, dampness as well as the interloper discovery. The yield appeared beneath means the temperature, soil dampness state with the gate crasher identification. The second outcome is the yield from the Android purpose that is produced in the cell phone. It decides the temperature, dampness, dampness with the gate crasher location.

## VI. CONCLUSION

Therefore, the paper proposes a thought of consolidating the most recent innovation into the agrarian field to turn the customary techniques for water system to current strategies in this way making simple profitable and temperate trimming. Some degree of mechanization is presented empowering the idea of observing the field and the product conditions inside some long-separate extents utilizing cloud administrations. The points of interest like water sparing and work sparing are started utilizing sensors that work consequently as they are modified. This idea of modernization of farming is straightforward, reasonable and operable. As relying upon these parameter esteems rancher can without much of a stretch choose which fungicides and pesticides are utilized for enhancing crop creation.

## REFERENCES

[1]. Joaquín Gutiérrez, Juan Francisco Villa-Medina, Alejandra NietoGaribay, and

Miguel Ángel PortaGándara, "Computerized Irrigation System Using a Wireless Sensor Network and GPRS Module", IEEE Transactions on Instrumentation and Measurements, 0018-9456, 2013.

- [2]. Dr. vidya devi, lockup. meena kumari, "continuous mechanization along with patrol process under the authority of most aerodynamic agriculture", universal newspaper made from appraisal furthermore probe contemporary scientific knowledge together with structures (ijrrase) vol3 no.1. pp 7-12, 2013.
- [3]. Meonghun Lee, Jeonghwan Hwang, Hyun Yoe, "Agrarian Protection System Based on IoT", IEEE sixteenth International Conference on Computational Science and Engineering, 2013.
- [4]. Paparao Nalajala, P Sambasiva Rao, Y Sangeetha, Ootla Balaji, K Navya," Design of a Smart Mobile Case Framework Based on the Internet of Things", Advances in Intelligent Systems and Computing, Volume 815, Pp. 657-666, 2019.



**International Journal of Advances in  
Engineering and Management**

**ISSN: 2395-5252**



# IJAEM

**Volume: 02**

**Issue: 01**

**DOI: 10.35629/5252**

**[www.ijaem.net](http://www.ijaem.net)**

**Email id: [ijaem.paper@gmail.com](mailto:ijaem.paper@gmail.com)**