

## HOME AUTOMATION SYSTEM USING ZIGBEE PROTOCOL

Mohit Sharma, Himanshu Chauhan, Harsh Rakesh Yadav, Jatin Kumar, Nidhi Sharma

*Department of Electronics and Communication Engineering, Noida Institute of Engineering and Technology*

Submitted: 25-06-2021

Revised: 01-07-2021

Accepted: 03-07-2021

### ABSTRACT

Automation is all around us. It is everywhere our eyes go to. Things nowadays are getting automated, either we take an example of Self Driven Cars, or we see the entry doors in the shopping malls, the escalators, automation is even there in the application we use around us, they can be the chatbots, the automated background processing, it cannot be neglected, it is everywhere. With Home Automation, we can make many electrical and electronic devices communicate and operate each other. As well as we can create an interactive interface for people so that they can operate the devices. By home automation a lot of energy can be conserved as the loss of energy can be avoided. And using some low-cost, low-energy consumption devices like ZigBee, we can achieve Home Automation in a more efficient way. Initially Bluetooth devices were used in home automation and some home automation systems use Wi-Fi module, but here we have tried to implement the home automation using the ZigBee module so that it can connect to more devices and can work for longer ranges than the previously used modules.

**KEY WORDS:** ZigBee IEEE 802.15.4, Methodology, Hardware Implementation, Software Implementation, System Implementation.

### I. INTRODUCTION

As we all know how lazy all humans are. All the laziness will come to a person when they are asked to switch ON/OFF the light fan or any other electrical device. And that laziness leads to loss of energy which is not so good not only this when people are not at home or someone handicap is there in a house it is difficult for them to make it to the electrical appliances. And to solve this problem we have to come up with the concept of Home Automation which makes the life easier as well we can cope up with the growing technology which is so important in today's life and as well as it reduces energy loss which is the main objective of Home Automation.

Home Automation generally means controlling of electrical or electronic devices by some wireless

techniques for which we are using ZigBee, an Arduino for communication of the system and to make them control each other.

### II. ZIGBEE IEEE802.15.4

ZigBee is a wireless technology developed by the Zigbee Alliance as an open global standard to address the unique needs of low-cost, low-power, wireless sensor networks [1].

ZigBee takes the advantage of IEEE 802.15.4 physical radio specification. Globally it operates in unlicensed bands of frequencies: 2.400–2.484 GHz, 902–928 MHz and 868.0–868.6 MHz. The type of ZigBee we have used in this project is XB Module S2C 802.15.4 2mW with Wire Antenna XB24CZ7WIT-004. We can send data up to 30m using this module and it takes just 1mW of power to transmit the data.

We can use ZigBee in 3 different modes. AT mode, API mode and API with Escape (ESC) character mode. And in this project, we are using it in API mode because of several reasons. The very main reason is that it can transmit data to multiple destinations without entering command mode. It can also connect to each packet through their source addresses, and it has an advantage that it will receive data on transmission status either it will be successful or fail.

### III. METHODOLOGY

This project has two sections: Hardware and Software Implementation. The hardware consists of the development and designing of main controller, ZigBee module, and relay module into a single circuit. While the software consists of microcontroller programming using embedded C.

#### A. Hardware Implementation:

In this section we have two circuits. First one is the receiver circuit and the other one is the transmitter circuit. The Arduino UNO on both the circuits is the main component of the hardware and this will act as an interface between the home appliances and Zigbee on the receiver circuit and as an interface between the switches and Zigbee on

the transmitter circuit. Our main controller i.e., Arduino UNO is based on ATmega328 8-bit Microcontroller having 14 digital Input/Output pins, 6 analog pins and a 16 MHz quartz crystal.

#### B. Software Implementation:

It is the programming part which means it consists of a set of instructions which we have written on our microcontroller. The programming part is done in both the circuits in two different ways. However, we are using two ZigBee modules and we know that it is a transceiver module. So, at the receiver circuit we have programmed the microcontroller to make the ZigBee work as a receiver and on the transmitter circuit we have

programmed the microcontroller to make the ZigBee work as a transmitter.

#### IV. SYSTEM IMPLEMENTATION

The project comprises of important features of Home Automation. In this system user can control the devices wirelessly by just pressing the switch from anywhere. Figure 1 Shows the how the receiver is sending data to the microcontroller and then the microcontroller sending instructions to the relay module so that relay module will know which device to turn ON/OFF. Figure 2 Shows that how the transmitter is connected to the microcontroller so that whenever the input is changed the microcontroller sends that data to the ZigBee and it transmits data to the receiver circuit.

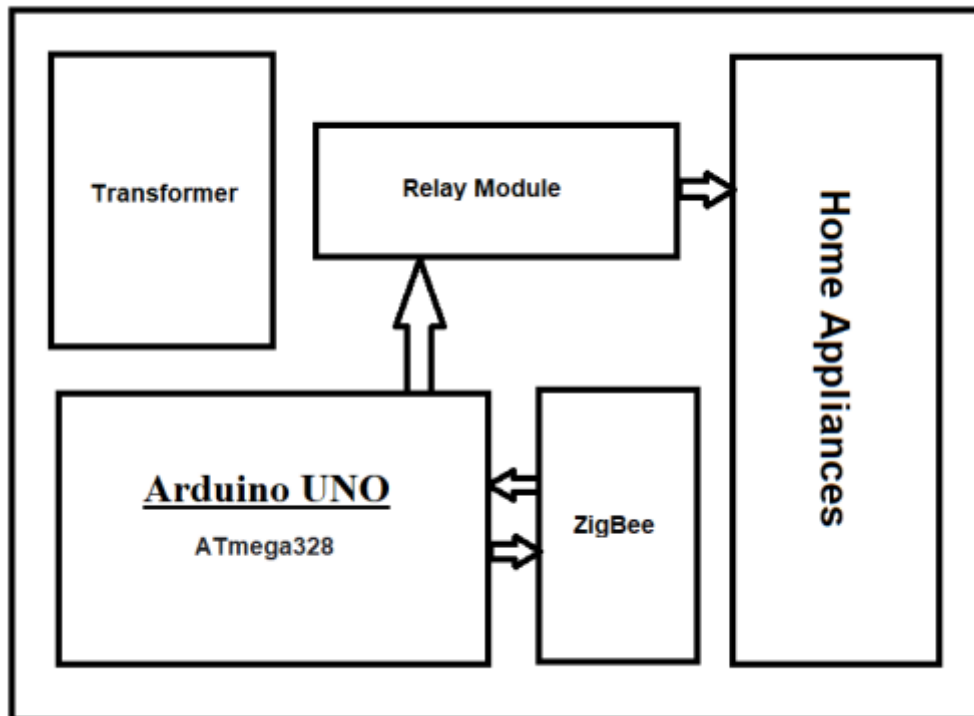

Fig 1: Receiver Circuit

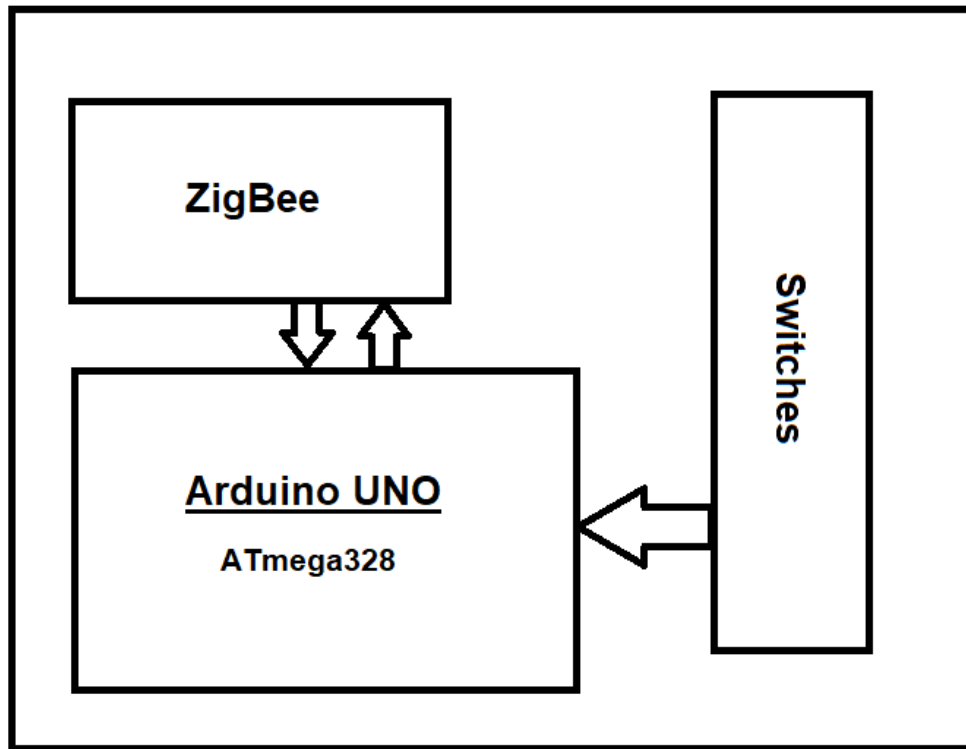

Fig 2: Transmitter Circuit

### V. COMPARISON TABLE

Table 1: Comparison of Bluetooth, ZigBee and Wi-Fi

Name	Bluetooth	ZigBee	Wi-Fi
IEEE Standard	802.15.1	802.15.4	802.11(a, b, g, n)
Frequency (GHz)	2.4	0.868, 0.915, 2.4	2.4 and 5
Maximum raw bit rate (Mbps)	1-3	0.250	11(b), 54(g), 600(n)
Typical data throughput (Mbps)	0.7-2.1	0.2	7(b), 25(g), 150(n)
Maximum (Outdoor) Range (Meters)	10 (class 2), 100(class 1)	10-100	100-250
Relative Power Consumption	Medium	Very low	High
Example Battery Life	Days	Months to years	Hours
Network Size	7	64,000+	255
Cost	Low cost	Low cost	High cost

### VI. RESULT

As a result of this project, A prototype of a home automation system consisting of a ZigBee module, a microcontroller, and relays has been implemented. Which works fine up to a range of 15 meters approx. When comparing to other modules in the market like Wi-Fi or Bluetooth, this range is much better than that on small range modules. Ranges of these modules vary as we go to the higher price variants of them. After surveying we also found that comparing ZigBee to other devices

at similar prices gives us the best range at ZigBee modules only.

However, if better ZigBee modules are used then ZigBee can range up to 15 miles whereas Wi-Fi stops at 300 ft. As ZigBee is also a low-cost device so by implementing the ZigBee module, we have found that ZigBee is a better choice to be used in Home Automation.

## VII. CONCLUSIONS

This paper shows the potential deployment of ZigBee communication Protocol in Smart Home Automation. An example of a prototype of implementation of ZigBee based wireless sensor network has been done. In this way, ZigBee can be an emerging network technology being a wireless communication standard that can be used to satisfy such Requirements. And if talking about the specifications the standard IEEE 802.15.4 wireless protocols, offers complete interoperability to the module.

## REFERENCES

- [1]. K. Balasubramanian and A. Cellatoglu, "Analysis of RemoteControl Techniques Employed in Home Automation and Security Systems", IEEE Magazine, vol. 48, issue 6, pp. 92 – 101, 2011. Liu Jian, Zhang Yixian "New Technology and Optimization of Mobile Phone Battery", May 2016.
- [2]. Gomez C., Paradells, J., "Wireless home automation networks: A survey of architectures and technologies", IEEE Communications Magazine, vol. 48, issue 6, pp. 92 – 101, 2010.
- [3]. Chun-Liang Hsu, Teng-Yaw Hsu, Kuan-Yen Ho, and Wei-Bin Wu "Practical design of intelligent living-space based on Bluetooth System", Maturitas, vol. 64, issue 2, pp. 90-97, 2009.
- [4]. Javier Castro and James Psota, "The Specification, Design, and Implementation of a Home Automation System", The American Journal of systems, 2009.
- [5]. Khusvinder Gill, Shuang-Hua Yang, Fang Yao, and Xin Lu, "A ZigBee-Based Home Automation System", IEEE Transactions on Consumer Electronics, Vol. 55, No. 2, MAY 2009.
- [6]. Michal Varchola, Milos Drutarovsky, "Zigbee based home automation wireless sensor network" IEEE PERCOM Workshops, pp. 141-146, 2011.
- [7]. Laur I., "Microcontroller based home automation system with security", International Journal of Advanced Computer Science and Applications, vol. 1, no. 6, pp. 60-65, 2010.