

Fatigue surveillance and safety enhancement using IoT

¹Pavithralakshmi G, ²Roobini S, ³Roshini P, Dr.T.Loganayagi,

*Students, Department of ECE, Paavai Engineering College, Namakkal, Tamilnadu, India.
ME., Ph.D, Associate Professor, Department of ECE, Paavai Engineering college, Namakkal, Tamilnadu, India.*

Submitted: 01-04-2021

Revised: 11-04-2021

Accepted: 14-04-2021

ABSTRACT: In Indian country the health level of vehicle driver is going abnormal while travelling. Because of this reason vehicle accident numbers are increasing day by day. For that we are designing a project called intelligent approach to monitor a health condition and drowsiness of a driver using IoT based system. The main objective of our project is to monitor a vehicle driver's health level, fire detection, fall detection and alcohol detection. The heart beat sensor is used to monitor the health level, in case of driver emergency the alarm is activated and vehicle automatically stopped and message is sent to nearby hospitals. Using an alcohol sensor we are testing a driver is drunken or not. Sensor detects the driver is drunken they automatically stop the vehicle and message received by traffic police server using to know the particular vehicle is drunken drive. This project describes a real-time, non-intrusive prototype for fatigue monitoring and mishaps prevention. It is a driver vigilance monitoring system which detect and alarm the user i.e driver. There are many measures for monitoring drowsiness based on monitoring the changes in vehicle, behaviour of driver and physiology of a person. They all have corresponding advantage and limitations. However for obtaining more accuracy the combination of these methods can be used. Hence here we developed a hybrid system which is a combination of behavioural based and physiological based. There are many parameters are available but in order to make simple and cheap detection system which will be suitable for everyone we take head movement and pulse rate as a parameter for this project.

KEYWORDS: Drowsiness monitoring system, driver's alcohol consumption detection, fire detection, fall detection, accelerometer, heartbeat sensor, petrol leakage sensor, Arduino Uno, IoT.

I. INTRODUCTION

Abruptly road accidents are increasing all over the world. There are many reasons for

accidents some of the major issues are lack of driver's vigilance which maybe because of drunk and drive, drowsiness or some health issues. The major problem in long driving is drowsiness. Drowsiness in drivers can be generally can be monitored by the following categories:

- Vehicle based measures
- Behavioural based measures
- Physiological based measures

[1] **Vehicle based measures:** Here sensors are placed on standard vehicle components i.e. Steering wheel and gas pedal. That sensor detects a deviation from lane position or loss of control over steering wheel movement. This method is non-intrusive. But it has limitation that it is unreliable since variation in individual and vehicle.

[2] **Behavioural based measures:** In this method alertness of a person is tracked from eye closure count, yawing count, eye blinking pattern, head pose and head movement. It is non-intrusive and easy to use. But it also has limitation that variation in background light.

[3] **Physiological based measures:** The sensor like ECG, EEG and EOG was used to measure drivers heart pulse and physiological change in order to detect drowsiness. This method has high accuracy and reliable. But it has limitation that it is intrusive, which is not realistic.

Hence in this project a real-time, non-intrusive prototype for fatigue monitoring and mishaps prevention system is designed. Generally vehicle tracking system is used for monitoring an own vehicle and a person having a vehicles like Lorry is monitored by owner by using IOT. Our project is mainly used for tracking a drunken vehicle driver to avoid the accident caused by a drunken driver. Because most the accidents is caused by drunken vehicle and rush driving. For that we are designed IOT based real time health monitoring system.

Using this project the traffic police easily find drunken drivers and take respective action. Different sensors are connected and driver health status monitoring. In this effective way driver drowsiness monitoring in real time using IOT.

II. RELATED WORKS

A fatigue driving alarm algorithm supported multi-feature comprehensive evaluation were in use which is straightforward and practical, and it utilized the PERCLOS method to hold on the analysis of the eye movement in fatigue state, uses eigenvalue to analyse the indexes of EMG, ECG, and grip strength, then implement the integrated fatigue judgment supported on the comprehensive evaluation method. The accuracy rate is 0.775. But it's costly and time required for analysis is high.

A multi-state create-dependent graded face form model is with success developed to boost the accuracy and lustiness of facial feature chase beneath synchronic pose variations and face deformations. The model permits to at the same time characterize the worldwide form constraints and therefore the native structural details of human faces form constraints for the feature search square measure considerably improved by modifying mean shapes through sturdy face create estimation. Feature purpose positions square measure dynamically calculable with multi-state native form models employing a multi-modal chase approach. Experimental results demonstrate that the planned methodology considerably reduces the feature chase error, compared to the classical feature chase ways. within the current work, we have a tendency to ignore the relationships between totally different completely different facial elements by decoupling the face into different native models, as a result of those relationships square measure advanced, dynamic, and extremely unsure. Moreover, incorrect modelling of such relationships can result in the failure in detection of facial feature.

A DMM system featuring a mobile and wireless EEG headgear with an on-line and real-time signal-processing platform. The systems portability and wear ability considerably improve the usability and practicality of the DMM system over traditional laboratory-oriented EEG-based brain-computer interface designs. But it's wearable and non realistic.

Many studies were conducted to analyse vital sign variability (HRV) alone, collected with graph or PPG sensors, that area unit comparatively straightforward to live. typical HRV-derived options utilized in several earlier studies typically centered on spectral changes. Such traits area unit

straightforward and straightforward to calculate, however aren't adequate to capture nonlinear dynamics of complicated systems. That is, they are doing not absolutely represent varied changes over time or trends shown within the RP.

Head-pose of the driving force is calculable by victimisation optical flow of the countenance, that area unit uninheritable with a corner detection formula. To estimate the gaze direction of the driving force, we have a tendency to trace the centre purpose of the pupil. The eye-blinking is calculable by victimisation the Integral Projection operate (IPF). Performance of the system is evaluated victimisation the new driver information. Result suggests that the system features a sensible potential for police work temporary state of the drivers.

III. PROPOSED SYSTEM

This paper describes a real-time, non-intrusive prototype for fatigue monitoring and mishaps prevention. It is a driver vigilance monitoring system which detect and alarm the driver using heartbeat sensor and accelerometer sensors which will produce a reliable and accurate results with cheap components. For enhancing safety alcohol sensor, petrol leakage sensor and fire sensors are used.

Heartbeat sensor: It is a device for holding a heartbeat sensor in a relatively fixed relationship with respect to the end of a user's fingertip. The MAX30102 is an integrated pulse oximetry and heart-rate monitor module. It includes internal LEDs, photodetectors, optical elements, and low-noise electronics with ambient light rejection. The MAX30102 provides a complete system solution to ease the design-in process for mobile and wearable devices. The MAX30102 operates on a single 1.8V power supply and a separate 3.3V power supply for the internal LEDs. Communication is through a standard I2C-compatible interface. The module can be shut down through software with zero standby current, allowing the power rails to remain powered at all times.

Accelerometer:An accelerometer is a tool that measures proper acceleration. The ADXL345 is a small, thin, ultralow power, 3-axis accelerometer with high resolution (13-bit) measurement at up to ± 16 g. Digital output data is formatted as 16-bit twos complement and is accessible through either a SPI (3- or 4-wire) or I2C digital interface. The ADXL345 is well suited for mobile device applications. It measures the static acceleration of gravity in tilt-sensing applications, as well as

dynamic acceleration resulting from motion or shock. Its high resolution (3.9 mg/LSB) enables measurement of inclination changes less than 1.0°. The ADXL345 is supplied in a small, thin, 3 mm × 5 mm × 1 mm, 14-lead, plastic package. It is a 3-Axis, ±2 g/±4 g/±8 g/±16 g Digital Accelerometer.

Alcohol sensor: A Breathalyzer or breathalyser (a portmanteau of breath and analyser /analyser) is a device for estimating blood alcohol content (BAC) from a breath sample. This alcohol sensor is suitable for detecting alcohol concentration on your breath, just like your common Breathalyzer. It has a high sensitivity and fast response time. Sensor provides an analog resistive output based on alcohol concentration. Here we use GS 106 which has high sensitivity to LPG, iso butane, propane and small sensitivity to alcohol, smoke.

Petrol leakage sensor: Electrochemical gas sensors are gas detectors that measure the concentration of a target gas by oxidizing or reducing the target gas at an electrode and measuring the resulting current. The sensors contain two or three electrodes,

occasionally four, in contact with an electrolyte. The electrodes are typically fabricated by fixing a high surface area precious metal on to the porous hydrophobic membrane.

Fire sensor: A fire detector incorporates a heat able gas sensor. The sensor is cycled through a plurality of different operating temperature ranges, and one or more outputs at each temperature range are acquired. A plurality of acquired outputs, corresponding to the plurality of temperature ranges, can be coupled in parallel to pattern recognition circuitry. The pattern recognition circuitry can process the acquired outputs and make a determination that the processed data samples are indicative of the presence of a fire condition. Here we use BPV10 which is a very high speed and highly sensitive PIN photodiode in a standard T-1^(1/4) plastic package. Due to its water clear epoxy the device is sensitive to visible and infrared radiation. It has Extra fast response times, High bandwidth B = 250 MHz at VR=12 V, High photo sensitivity and Radiant sensitive area A=0.78mm²

Block diagram of proposed system

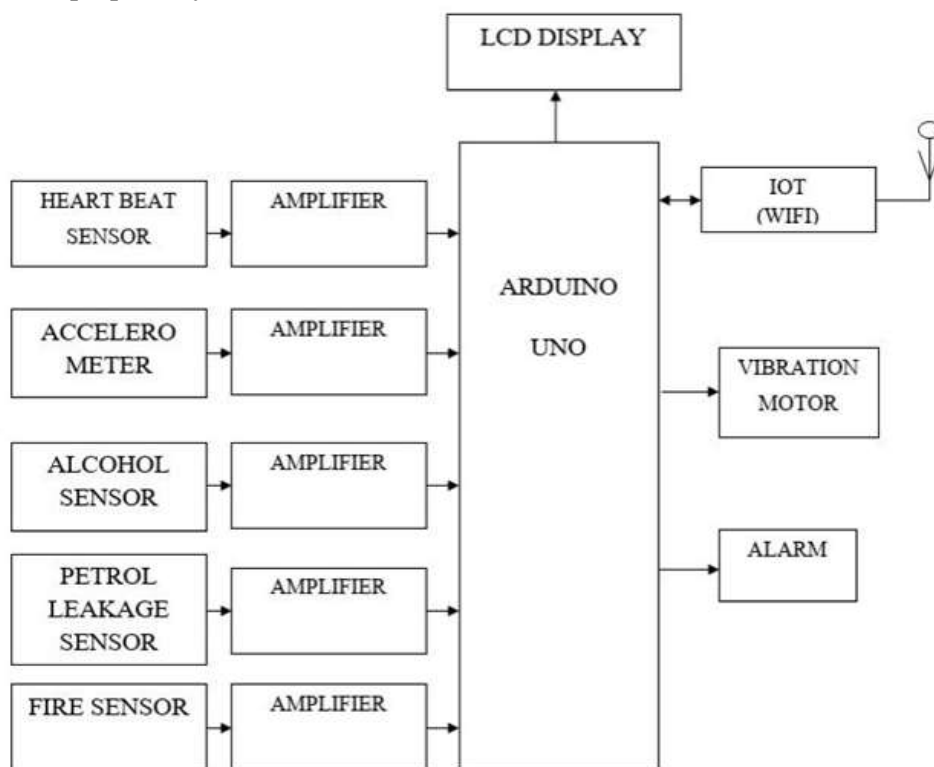

IV. EXPERIMENTATION

A Regulated 5V DC power supply from vehicle battery is feed to Arduino board and other components. All components of our system operate at low voltages and require a small amount of current to operate. The heartbeat sensor (MAX 30102) and accelerometer (ADXL345) are the main components. The MAX 30102 counts the heartbeat for 7 seconds and convert it for a minute. If there is an abnormal heartbeat rate the Arduino calibrate and displays an abnormal heartrate in LED. The ADXL345 which is 3 axis accelerometer sense the

abnormal heat movement and the message sleep detected will be displayed on LED and alarm along with vibration motor are activated. The GS 106 and petrol leakage sensor detect the presence of gasses and set alarm along with the indication of gas detected message in LED. The fire sensor (BPV 10) detects the presence of fire and sent the message along with alarm. The IoT module with internet access sent he data for every 7 seconds to the IoT server where the data are stored along with graphical chart.



TOP VIEW OF FATIGUE SURVEILLANCE AND SAFETY ENHANCEMENT KIT

SOURCE CODE FOR THE ARDUINO IDE:

```

#include "HX711.h"
#include <LiquidCrystal.h>
LiquidCrystalled(13,12,11,10,9,8);
//HX711 scale(3, 2); //HX711 scale(6, 5);
#include <SoftwareSerial.h>

String AP = "root"; // CHANGE ME
String PASS = "root12345"; // CHANGE ME
String API = "LYMXVUG59J7ARING"; //
CHANGE ME
String HOST = "api.thingspeak.com";
String PORT = "80";
String field1 = "field1";
String field2 = "field2";
String field3 = "field3";
String field4 = "field4";
String field5 = "field5";
String field6 = "field6";

int
Temp,Level,pol,dir,spd,dirr,xaxis,yaxis,zaxis,gas,al
cohol,acc,hb,temp,bat,mic,hum,sett,force;
int speed1,spe,speed2;
unsigned char xx = 0;
unsigned char irv,irvv,irvvv,sec6,yu=0,val[20];

```

```

String irv2;
intcountTrueCommand,sec=0,secc=0;
intcountTimeCommand;
boolean found = false;
intvalSensor = 100;

int alarm=A5;
int motor=A4;
int fire=2;

float units;
float ounces;

void setup()
{
Serial.begin(9600);
pinMode(alarm,OUTPUT);
pinMode(motor,OUTPUT);
pinMode(fire,INPUT);
digitalWrite(alarm,LOW);
lcd.begin(16, 2);
lcd.setCursor(0,0);
lcd.print("-----");
lcd.setCursor(0,1);
lcd.print("-----");delay(200);

```

```

lcd.clear();
}
void loop()
{
acc=analogRead(A0)>>2;
lcd.setCursor(0,0);
lcd.print("A:");
Lcd_Decimal3(2,0,acc);

hb=analogRead(A1)>>2;
lcd.setCursor(6,0);
lcd.print("H:");
Lcd_Decimal3(8,0,hb);

alcohol=analogRead(A2)>>2;
lcd.setCursor(11,0);
lcd.print("a:");
Lcd_Decimal3(14,0,alcohol);

gas=analogRead(A3)>>2;
lcd.setCursor(0,1);
lcd.print("gas:");
Lcd_Decimal3(4,1,gas);

if(digitalRead(fire)==HIGH)
{lcd.setCursor(0,0);lcd.print("FIRE
SENSENING");digitalWrite(alarm,HIGH);
lcd.setCursor(12,1);lcd.print("DATA");http_send1(
);
}
sec++;be

if(sec>50){secc++;sec=0;}

if(secc>10){http_send1();delay(500);sec=0;secc=0;
}
}

void http_send1()
{
Serial.print("http://mangocity.appblocky.com/webd
b/storeavalue.php?tag=force&value=");
Serial.print(xaxis);

Serial.print(",");//Serial.write(0x0d);Serial.write(0x
0a);delay(2000);
Serial.print(yaxis);

Serial.print(",");//Serial.write(0x0d);Serial.write(0x
0a);delay(2000);
Serial.print(zaxis);

Serial.print(",");//Serial.write(0x0d);Serial.write(0x
0a);delay(2000);
Serial.println(force);

//Serial.println("http://mangocity.appblocky.com/w
ebdb/getvalue.php?tag=agriread");
//http://mangocity.appblocky.com/webdb/getvalue.
php?tag=agriread
}

```

Table of output:

S.NO	TIMING	ENTRY ID	FIELD 1 (ADXL 345)	FIELD 2 (MAX 30102)	FIELD 3 (ALCO HOL)	FIELD 4 (GAS)	FIELD 5 (STATUS)
1	2021-04-03 10:41:12 UTC	205	66	0	21	30	NORMAL
2	2021-04-03 10:41:33 UTC	206	66	0	20	30	NORMAL
3	2021-04-03 10:41:55 UTC	207	66	0	17	29	NORMAL
4	2021-04-03 10:42:16 UTC	208	60	0	18	28	NORMAL
5	2021-04-03 10:42:37 UTC	209	61	31017	16	27	HEARTBEAT ABNORMAL
6	2021-04-03 10:43:18 UTC	210	75	0	16	26	SLEEPING ALERT
7	2021-04-03 10:43:39 UTC	211	58	0	17	26	NORMAL
8	2021-04-03 10:44:46 UTC	212	58	0	17	19	FIRE DETECTION
9	2021-04-03 10:46:00	213	60	0	16	196	GAS DETECTION

10	2021-04-03 10:46:24 UTC	214	59	0	20	15	NORMAL
----	----------------------------	-----	----	---	----	----	--------

Output graphical representation



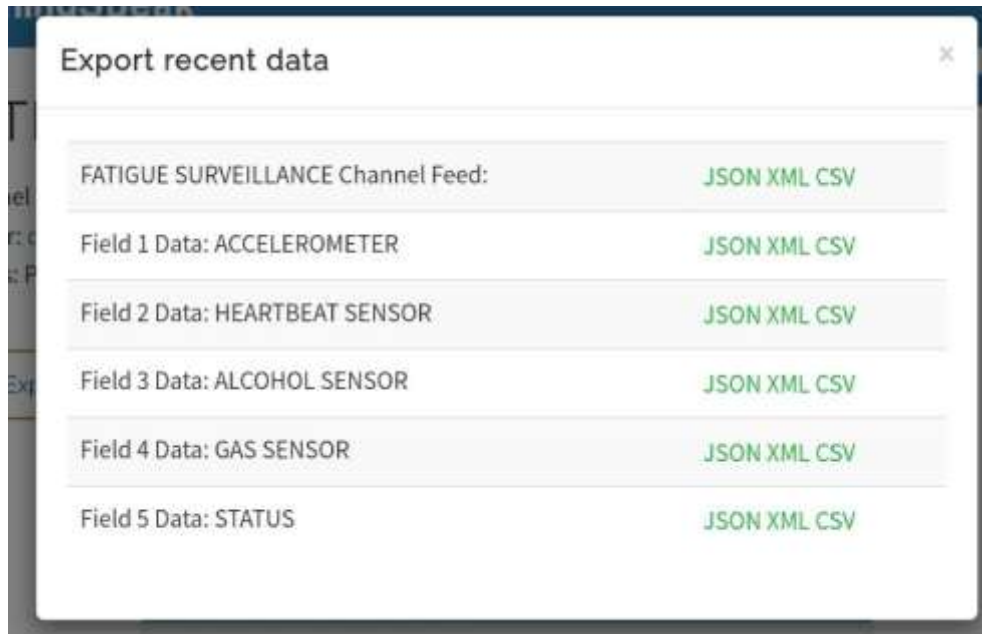

V. CONCLUSION

In our project driver's drowsiness is monitored to avoid chances of accident. Along with drowsiness, driver's health level, fire and alcohol status are monitored with sensors and messages sent via WI-FI to IoT server or android app. The main feature is we used heart beat sensor and accelerometer for tracking. This is a low cost system with improved accuracy which is suitable for real time application.

By using IoI for fatigue surveillance and safety enhancement we are tracking transport vehicle driver's health level to avoid the chances of accidents. In fact most of the accidents are because of drunken drive. Here the output of heartbeat sensor, accelerometer, petrol leakage sensor and fire sensor are monitored and processed. Then the message related to output sent via Wi-Fi to IoT server or android app.

Using this project we can easily monitor the health level and traffic police easily find drunken drivers and take respective action. Different sensors are connected and monitoring driver condition. By this effective way we track vehicle in real time. The main feature of this project is monitoring both heart beat level to monitor health level driver and also detect the drunken Drive. In future we are planning to add some advanced features for increasing accuracy.

SOME OF THE ADVANAGES FROM THE ABOVE RESULTS

- a) Low cost and simple circuit.
- b) Enhanced accuracy.

- c) Basic coding knowledge alone is required.

REFERENCES

- [1]. Cell-phone Based Drowsiness Monitoring and Management System Yu-Te Wang, Chung-Kuan Cheng Department of Computer Science and Engineering University of California San Diego La Jolla, USA. Kuan-Chih Huang, Chin-Teng Lin Institute of Electrical Control Engineering National Chiao-Tung University Hsinchu, Taiwan Yijun Wang, Tzyy-Ping Jung Institute of Engineering in Medicine Institute for Neural Computation University of California San Diego La Jolla, USA
- [2]. Detecting Driver Drowsiness using Wireless Wearables Brandy Warwick, Nicholas Symons, Xiao Chen Department of Computer Science, Texas State University, San Marcos, TX. Kaiqi Xiong College of Computing and Information Sciences, Rochester Institute of Technology, Rochester, NY
- [3]. Driver drowsiness monitoring based on yawning detection Conference Paper in Conference Record - IEEE Instrumentation and Measurement Technology Conference · May 2011 Navaneetha Varier, Abhishek Sehgal, T. Balachander, "Smart Speed Breaker System Using Internet of Things" International Journal of Pure and Applied Mathematics Vol 118 No.22 2018, 415-419.

- [4]. Drowsy Driver Detection through Facial Movement Analysis Conference Paper: November 2007 DOI: 10.1007/978-3-540-75773-3-2 Source: dx.doi.org
- [5]. Head Pose and Gaze Direction Tracking for Detecting a Drowsy Driver. Real-time system for monitoring driver vigilance. Article in Applied Mathematics & Information Sciences · March 2015. DOI: 10.12785/amis/092L25
- [6]. Real-time system for monitoring driver vigilance. Article in IEEE Transactions on Intelligent Transportation Systems · January 2006 DOI:10.1109/ISIE.2005.1529113· Source: DBLP
- [7]. Research on Drowsy driving monitoring and Warning System Based on Multi-feature Comprehensive Evolution Zhipeng Ma, Shuwan Yan, Jian Zhaa, Jingjiu Qian, Jun Su, Jingshuang Dai College of Automotive Engineering, Jilin University, Changchun, 130022 China College of Mechanical Science and Engineering, Jilin University, Changchun, 130022 China, ASCL & College of Automotive Engineering, Jilin University, Changchun, 130022 China.
- [8]. Robust facial feature tracking under varying face pose and facial expression Yan Tonga, Yang Wangb, ZhiweiZhucQiangJia,*department of Electrical, Computer, and Systems Engineering, Rensselaer Polytechnic Institute, Troy, NY 12180-3590, National ICT Australia, Eveleigh, NSW 1430, AustraliaSarnoff Corporation, Princeton, NJ 08543-5300, USA
- [9]. Using Wearable ECG/PPG Sensors for Driver Drowsiness Detection Based on Distinguishable Pattern of Recurrence Plots Hyeonjeong Lee 1, Jaewon Lee 1 and Miyoung Shin, Bio-Intelligence & Data Mining Laboratory, School of Electronics Engineering, Kyungpook National University, Daegu 41566, Korea; leehj1224k@gmail.com(H.L.); realjaewon94@gmail.com (J.L.), School of Electronics Engineering, Kyungpook National University, Daegu 41566, Korea Received: 30 December 2018; Accepted: 1 February 2019; Published: 7 February 2019
- [10]. Vision-based drowsiness detector for real driving conditions Conference Paper · June 2012 DOI: 10.1109/IVS.2012.6232222



**International Journal of Advances in
Engineering and Management**
ISSN: 2395-5252



IJAEM

Volume: 03

Issue: 04

DOI: 10.35629/5252

www.ijaem.net

Email id: ijaem.paper@gmail.com