

# Electric lineman safety using Arduino UNO and fingerprint scanner

Darshan H M, Mrs. Shailashree K

Dept. of EEE JNN college of Engineering Shivamogga, India  
Dept. of EEE JNN College of Engineering Shivamogga, India

Submitted: 15-09-2021

Revised: 25-09-2021

Accepted: 28-09-2021

**ABSTRACT**— A world without electricity is hard to imagine. Electricity is currently become an area of our existence. Electricity plays major role in each homes & industries. Most devices at homes and industries area unit running owing to electricity. As how, the electricity is very important in our life the electricians' life is additionally predominant one. They play the numerous roles in their field. The proposed system focus on safety of the electric lineman who works with high voltage and risks from the sudden electric shocks while working on field . Each lineman needs to deal with live wires very often where chances of electrical accidents are very high due to miscommunication between substation staff and on-field electric lineman. In order to avoid this situation of risk there should be a safety measures which leads to developing this project “Electric lineman safety using Arduino UNO and fingerprint scanner”. The proposed system ensures safety of lineman. The planned system is totally operated on Arduino. This project mainly involves NodeMCU, Fingerprint scanner, Keypad, LCD display and Arduino UNO.

**Keywords**—Arduino UNO ,LCD display, Fingerprint scanner

## I. INTRODUCTION

During planned system , In case there is fault in line, lineman scans finger because of that route is converted at that time he's employed on line finding matter and at that time once more scans his finger and start the electrical line dominant one. During this planned system management (ON/OFF) lies with lineman.

Security is lot of vital in our day to day life. Everybody wants a lot of security .Nowadays, electrical danger to lineman area unit increasing, whereas repairing electrical lines because of shortage of communication between the electrical station and service staff. planned system provides an answer that ensures safety of electrical lineman , lineman on detection a fault in electrical line lineman senses his

finger through fingerprint scanner and therefore route converted that is once more switch on. when finding fault once more sensing a finger, therefore it saves lifetime of lineman acting on electrical line. This planned sys is completely operated on Arduino.

The management to show on/off line are maintained through lineman only as a result of this technique has a rendezvous such a fingerprint device is needed to control the electrical fuse (on/off). System is totally controlled by MC.

interface, which then sends them to the Chatbot application. A pre-processing stage is performed on the textual inquiry in the application. Tokenization is a pre-processing phase in which the query sentence is tokenized into words, the stop words are deleted, and the words are stemmed to root words. Then the query would be classified using a neural network

## II. METHODOLOGY

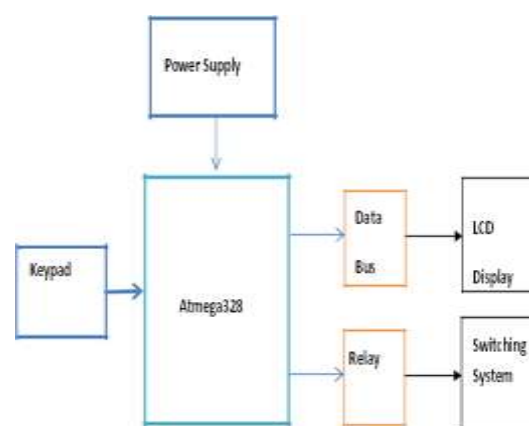

Fig 1: User Side Block Diagram

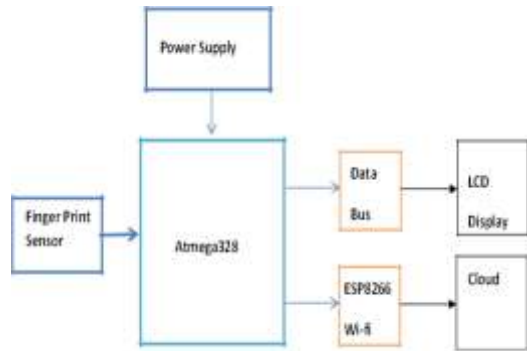

Fig 2: Substation Block Diagram

The first block diagram shows user side or lineman side and second block diagram indicates admin side or substation side block diagram. Microcontroller, which has the capabilities to run 24 hours a day, and 7days a week. In this project, it is being used as the brain of the entire system to control the system.

The user side block diagram consist of fingerprint scanner, LCD display, nodemcu and arduino MC. The arduino microcontroller is heart of the proposed system. FP connect to Microcontroller, if fingerprint stored is authenticated fingerprint now the mcu on, on and off the relay which may help for controlling line by linemen. If there is any fault in the electric line then through the fingerprint scanner he can sense his finger and then he can turn off line and after clearing the fault he can turn on line,

The turn on and turn off electric line is controlled by the corresponding area electric lineman. When the person FP is changed, fingerprint scanner does not takes. so that in such situation, the electrician difficult to identify themselves so now the admin can control the line.

The substation side consists of 4x3 keypad , microcontroller, relay, 16x2 LCD display and nodemcu. keypad is connected or interfaced to the microcontroller. Wiring 4x3 keypad with the microcontroller is simple like connecting the first pin of the keypad to the digital pin nine of arduino, currently keep connecting the pins leftwards like a pair of with eight.If lineman not able to turn on the line after clearing the fault then admin On the line after entering the 4 digit password through 4x3 keypad. When admin enter four digit password in the keypad then lcd shows or display admin authentication base station switching, now the admin can control the line. The four digit password is share only between the admin and corresponding area linemen.

### III. FLOWCHART



Above flowchart mainly describes about fingerprint authentication.

### IV. RESULT AND ANALYSIS

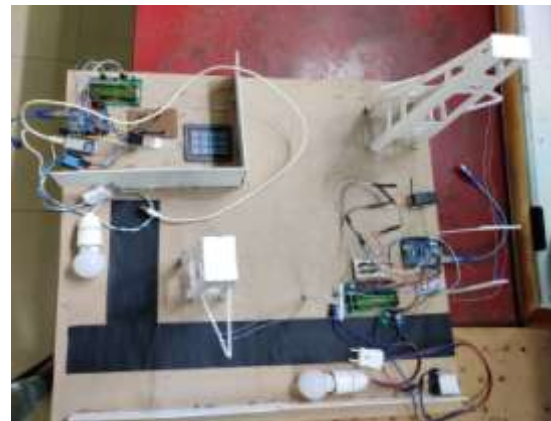

Step 1: Overview of the project

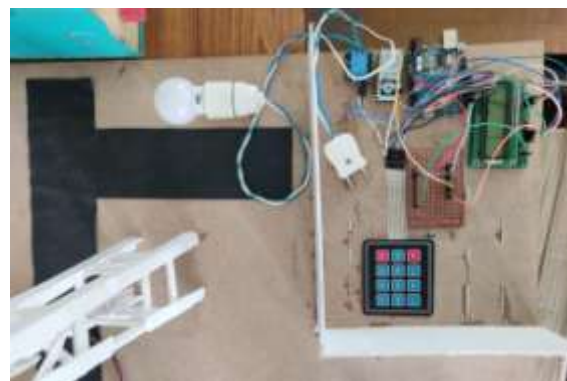

Step 1(a): Admin side end

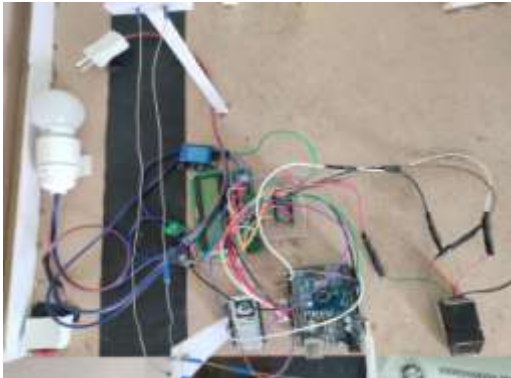

Step 2(b): lineman side



Step 5: Display to show admin authentication base station switching that is after entering the 4 digits password in keypad



Step 2: Display to show Welcome to Lineman safety system



Step 6: Snapshot of Blynk application that shows repair status and theft detection.



Step 3: Display to show lineman authentication base station switching that is lineman after sensing his finger through fingerprint scanner.



Step 4: Display to show Power theft detection at lineman side

## V. CONCLUSION

Technology is ruling the world nowadays, but it should erase the problems for our development. The proposed safety system successfully designed. It provides a new approach to the security of the lineman also completely eliminates the fatal electrical accidents to the lineman due to electric shock during the power line repair. It has been developed by integrated features of all the hardware components used. This paper can be extended for many electrical lines. All electrical lines can be controlled using corresponding area lineman. Fatal electrical accidents to lineman are increasing during the electric line repair due to lack of communication and coordination between the maintenance staff and electric substation staff. Hence in order to avoid this problem, this proposed system provides a solution, which provides safety to lineman.

## VI. FUTURE SCOPE

This project can be extended for many electrical lines. linemans can control area lines. The On/OFF time information about the electrical line is informed through LCD display and handle by the lineman. The further application of this proposed project is listed below

- Can be use in safety purpose.

- Can be used for security reasons.
- Used in Fault findings.
- Most useful to operate in public area.

#### REFERENCES

- [1] “**Arduino Based Protection System for Wireman**,” Int. J. Electr. Electron.Res., vol. 3 no. 1, pp.[1] Viral P. Solanki, Ajit J. Parmar, Nikul S. Limbachiya, RakeshKoringa, and Shivangi 76–79, 2015.
- [2] J.Veena, G.Srivani, Afreen, M.Sunil Kumar, J.Santhosh, and K.B.V.S.R.Subrahmanyam, “**Electric Lineman Protection Using User Changeable Password Based Circuit Breaker**,” Int. J. Curr. Eng. Sci. Res., vol. 2, no. 5, pp. 44–49, 2015.
- [3] P. N. Mahadik, P. A. Yadav, S. B. Gotpagar, and H. P. Pawar, “**Electric Line Man Safety using Micro Controller with GSM Module**,” Int. J. Sci. Res. Dev., vol. 4, no. 1, pp. 205–207, 2016.
- [4] A. M. Hassan Ali, “**Enhancement of a GSM Based Control System**,” in Advances in Circuits, Systems, Signal Processing and Telecommunications , 2015, pp. 189–202.
- [5] **Electric Line Man Protection Using User Changeable Password Based Circuit Breaker** 1J.Veena, 2G.Srivani, 3Afreen, 4M.Sunil Kumar, 5J.Santhosh, 6K.B.V.S.R.Subrahmanyam 1,2,3,4,5BE Students, 6Associate Professor, SR Engineering College.
- [6] National Electrical Safety Code Committee, Accredited Standards Committee C2 Rule 441 Table 441-1 AC Live Work Minimum Approach Distance (2002 Edition, page 228) IR540.
- [7] N. Nichols and D. D. Shipp, “**Designing to avoid hazardous transferred Earth potentials**,” IEEE Trans. Ind. Appl., vol. IA-18, no. 4, pp. 340 347, Jul. 1982.
- [8] **ELECTRIC LINE MAN SAFETY SYSTEM WITH OTP BASED CIRCUIT BREAKER** Athira P Nair<sup>1</sup>, Josephin J2, Anjana A S<sup>3</sup>, Athira C P<sup>4</sup>, Sebin J Olickal<sup>5</sup> 1Student, Dept. of Electronics& communication, BTC College of Engineering, Koothattukulam, Kerala 2Student, Dept. of Electronics& communication.
- [9] **Electric Line Man Safety using Micro Controller with GSM Module** IJSRD - International Journal for Scientific Research & Development| Vol. 4, Issue 01, 2016.