

# Development and Preliminary Testing Of a Bambara Groundnut Sheller

<sup>1</sup>Abdulkadir S. A., <sup>1</sup>Zamdayu, W. J and <sup>2</sup>Dodo M. S.

<sup>1</sup>Department of Agricultural & Bioenvironmental Engineering Technology Adamawa State Polytechnic, Yola

<sup>1</sup>Department of Mechanical Engineering Technology Adamawa State Polytechnic, Yola

Submitted: 10-10-2021

Revised: 19-10-2021

Accepted: 22-10-2021

## ABSTRACT

A centrifugal Bambara groundnut pod-shelling machine was designed and constructed to crack various sizes and varieties of bambara groundnut. The Sheller was fabricated with locally available materials. The concept of the new designed aimed at easing the pain, stress, intensive labour, time consumption, and the cumbersome operation encountered in the traditional method of shelling. The machine consists of three main units, namely the hopper, shelling unit and power transmission unit. The Sheller uses impact technique and was designed to shell Bambara groundnuts effectively and to eliminate drudgery associated with the traditional methods of shelling legumes. Five hundred (500) samples of sundried Bambara groundnuts at 6% (wet basis) which were randomly selected were shelled at an impeller rotation speed of 1636 rpm. The results of the test showed that the shelling efficiency, seed damage, partially shelled pods, unshelled pods and the machine capacity were 83.2%, 17.4%, 7.8%, 9%, and 75000 seeds/hr. respectively.

**Keywords:** Centrifugal, Shelling, Pods, Impeller, Transmission

## I. INTRODUCTION

Bambara groundnut (*Vigna subterranea* (L. verdc.) is an indigenous African crop grown across the continent from Senegal to Kenya and from the Sahara to South Africa. Bambara groundnut belongs to the family of Fabaceae and sub family of Faboidea. Bambara groundnut is the third most important grain after groundnut and cowpea. According to Tanimu and Aliyu (1995), bambara groundnut is widely cultivated throughout Nigeria, especially in the Sudan, Sahel, forest and southern Guinea zones with exception of the swampy and riverine areas. In separate reports by Ezue (1977), Atiku (2000), it was noted that in Nigeria the bambara groundnuts is widely produced in Borno, Anambra, Plateau, Taraba, Sokoto, Bauchi, Benue, Yobe, Adamawa, Gombe,

Enugu, Kogi and Oyo states. Although occasionally grown in Asia, its cultivation is rare outside the African continent. The distribution of wild Bambara groundnut is known to extend from Jos to Plateau and Yola in Nigeria, to Garoua in Cameroon. It is in West Africa that most of the world's Bambara groundnut is grown and is most prominent in the traditional rural communities. Bambara groundnut plays a key role in the traditional food and culture of the people in the western part of Africa. Bambara groundnut is now widely distributed in the semi-arid zone of sub Saharan Africa (SSA).

Often called bambara groundnut, it is conventionally classified as a bean but its seed is actually dug from the ground like the peanut. To outsiders, only the shape seems unusual. The pods are larger and rounder than peanut shells and the seeds inside are shaped more like beans than peanuts. The seed is hard, smooth, usually round and varies in size up to about 1.5 cm in diameter (Kay, 1979). These spherical legumes are however exceptionally tasty and nutritious. They are also attractive as they appear in various colours and patterns, characterized by appealing local names such as dove eyes, nightjar, and butterfly (National Research Council, 2006).

Traditional technologies are still employed in the shelling of bambara groundnut. These pod shelling methods vary from locality to locality depending on the quantity produced. These includes pounding in a mortar and pestle, beating with a stick on a flat surface and cracking with a stone on top of another stone or a hard flat surface (Atiku, 2000). These techniques are not only laborious and time consuming but also wasteful. As a result, the shelling of bambara groundnut pod has constituted a bottleneck to the large scale production and processing of the crop. To solve this problem and relieve the processors of the tedium of the manual shelling operation, a mechanical device that is capable of shelling the

Pods to produce clean seeds should be designed and fabricated.

A mechanical nutcracker is characterised by significant kernel breakage although some of the nuts are discharged uncracked (Obiakor and Babatunde, 1999). The breakage of the kernels results partly because the kernels upon release from the nut shell rebound in the cracking chamber and are subject to secondary impacts, which include breakage. Generally, agricultural materials including Bambara are non-homogeneous and some variations do occur in the properties of the nuts of the same size. Thus, the force required to break the nuts is not the same. Also the interaction between adjacent nuts may obstruct the direct impingement of the individual nut to the cracking wall so that some of the nuts are discharged untracked.

The works of Oje et al. (1997), Adigun and Oje (1993) revealed that the orientation of the nuts affected the cracking. Experimentation by these researchers on sheanut, thevetia nut, and irvingia nut showed that the orientation of nuts affected the energy requirements for the cracking of the nuts. The lateral position of the nuts was reported by these researchers to require minimum energy for cracking when compared with the longitudinal and axial orientation. Thus, to effectively design and construct a mechanical nut cracker, the physical and mechanical properties of the agricultural material must also be studied. Alonge and Idung (2015) developed a nutcracker for bush mango based on some engineering properties earlier studied.

Manual shelling of bambara groundnut has been a major bottleneck in the utilisation of bambara nut and as such, a mechanised method of shelling is continuously being appraised. Atiku et al. (2004) obtained 80% shelling efficiency using a roller and pneumatic mechanism operated sheller at pod moisture content of 5% (wb) and feed rate of 93.6 Kg/h. Adigun and Oje (1993) argued that the centrifugal cracker can easily crack nuts whose pods cannot be easily broken by the roller cracker. Based on this submission, Akani et al. (2000), Oluwole, Abdulrahim and Olarere (2007) and Oluwole, Abdulrahim and Oumarou (2007), laid more emphasis attention on the centrifugal impact cracker and obtained best efficiency (96%) at pod moisture content of 5.3% (wb), but these machines are somewhat complex, cumbersome and expensive, especially as they come with a winnowing unit to the small and medium scale operators in the rural areas. Thus the need to design a simpler, easy to operate and affordable machine for the rural dwellers that will handle the shelling

operation of the bambara groundnut. The objective of this study is therefore to design and fabricate a simple and inexpensive bambara groundnut sheller using locally sourced materials.

## II. MATERIALS AND METHODS

### Design Considerations

The sheller was designed based on the following considerations:

- i. The machine has to be affordable.
- ii. The nuts to be cracked will be sundried to a moisture content of about 5 - 8% w.b for greater efficiency (Akani et al., 2000).
- iii. Materials used will be suitable for the purpose of the design.
- iv. To have a higher capacity compared to manual operations.
- v. Design to be made simple for easy maintenance and dismantling when necessary

### Working principle

The working principle is based on the concept of energy absorbed by the seed as a result of impact between the seed and the wall of the cracking unit, which will then cause the removal of the pods. To operate the machine, the main switch is turned on to actuate the electric motor which runs the impeller in the cracking chamber. As the impeller reaches its operating speed, the seeds are fed manually into the hopper. The incoming nuts slide and roll on the inner surface of the rectangular pipe. The centrifugal force developed as a result of the rotation of the impeller throws the nuts against the cracking surface and causes the nuts to be shelled.

### Description of the Sheller

The machine consists of a feed hopper, the cracking chamber, impeller, shaft, bearings, pulley, frame and an electric motor. The machine has three major sections, namely the hopper, the pod shelling unit and the power transmission unit. The frustum framed hopper is fixed to the cracking unit top cover, the shelling unit consists of a 400 mm diameter by 100 mm height cylindrical shell made from mild steel sheets whose inner surface serves as the cracking surface. The impeller is made from a 25 mm by 50 mm rectangular steel pipe, with slots positioned 45° to the tangents of the slot outlet (Oluwole, Abdulrahim and Oumarou, 2007). A shaft drives the impeller through a system of pulley and belt, placed in a concentric and horizontal manner with the allowance between impeller and cracking wall greater than the size of the pod. These components are assembled and mounted on a rectangular tool frame that gives the machine a compact design (Figure 1).



Figure 1. Bambara groundnut Sheller

**Design methodology**

The design of the sheller was carried out with reference to Oluwole et al. (2004). The factors which affect the shelling of the pods as stated by Babatunde and Okoli (1988) and Atiku et al. (2004)

has been taken into consideration. The machine consists of the following components, namely a hopper, impact drum, impeller, shaft, bearings, pulleys, V-belt, electric motor and a support frame.

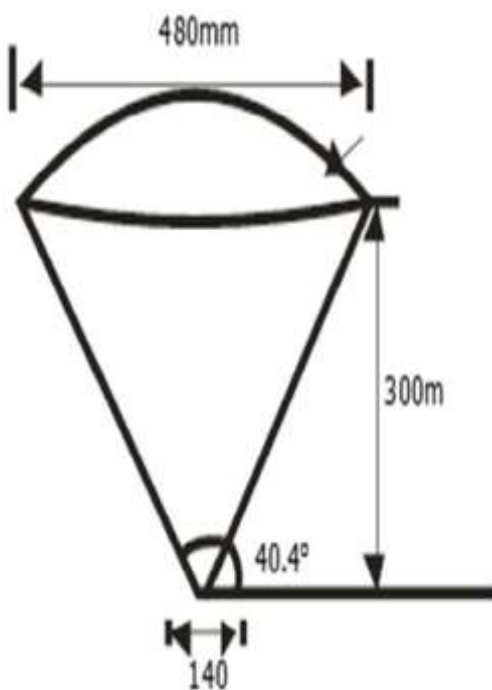

Figure 2. Hopper dimensions

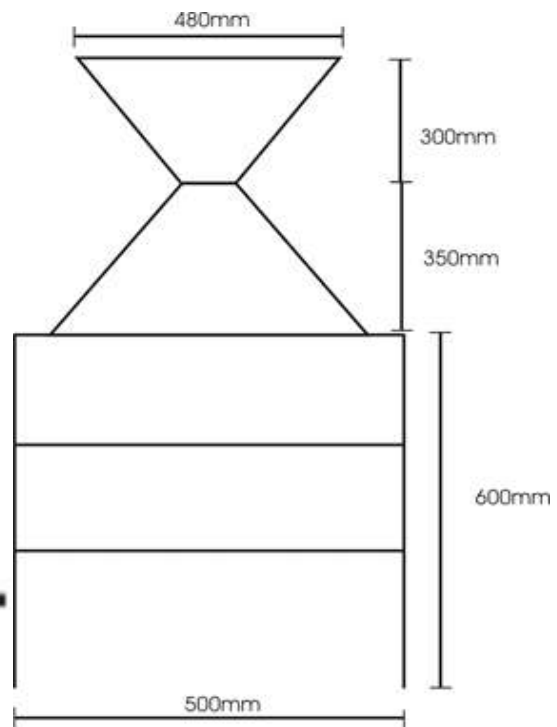

Figure 3 Orthographic Drawings

### Design Calculation

#### Hopper

The most important criteria in the design of the hopper is the angle of repose. According to Atiku (2004), the angle of repose for bambara groundnut is 30.4° at 5% moisture content (wb). Etoamaihe and Ndubueze (2010) observed that to avoid arching and tunnelling during discharge, angle of inclination of hopper should be 10° higher than natural angle of repose of stored material. Inclination angle of 40.4° was thus utilized for the hopper design. The hopper is in the form of a frustum (Figure 2) formed from a right circular cone made from galvanized steel. The volume was determined as 0.025 m<sup>3</sup> from equation 1.

$$V = \frac{\pi h}{3} (R^2 + R^2 r^2 + r^2) \quad \text{----- (1)}$$

Where: V = volume of hopper (m<sup>3</sup>), R = radius of upper base (0.24 m), r = radius of lower base (0.07 m), h = height of hopper (0.3 m).

$$V = \frac{3.142 \times 0.3}{3} (0.24^2 + 0.24 \times 0.07 + 0.07^2) \quad V = 0.0249 \text{ m}^3$$

#### Impeller

According to Ismail et al. (2015), Kinetic energy of bambara groundnut = impact energy of nuts on the cracking wall

$$\frac{1}{2} mv^2 = E \quad \text{----- (2)}$$

Where; v = velocity required for cracking (m/s), m = mass of nut (kg), E = energy of deformation (Nm)

At nut moisture content of 5 – 8%, Akani et al. (2000) and Atiku et al. (2004) determined optimum impact energy (energy of deformation) and average mass as 0.59 J and 0.00124 kg respectively.

$$v = 30.85 \text{ m/s}$$

$$\omega = \frac{v}{r} \quad \text{But } \omega = \frac{v}{r} \quad \text{(Khurmi and Gupta, 2006) ----- (3)}$$

For a shelling impeller radius, r = 180 mm, ω is determined as 171.39 rad/s

$$\omega = \frac{2\pi N}{60} \quad \text{Also, } \omega = \frac{2\pi N}{60} \quad \text{----- (4)}$$

Where N = rotational speed N is determined as 1636 rpm.

Linear speed required = 30.85 m/s

Angular speed required = 171.39 rad/s Rotational speed required = 1636 rpm

#### Shaft

Olakanmi (2004) expressed the force required to shell nuts like bambara groundnut as

$$F = \mu (w + 2m\omega^2) \quad \text{----- (5)}$$

Where; F = shelling force (N), μ = coefficient of friction of nut on steel, 0.56 (Atiku et al., 2004), m = average mass of bambara groundnut, 0.00124 kg ω = angular velocity, 171.39 rad/s, w = mean weight of bambara groundnut, (0.00124\*9.8)=0.012152 N F = 40.78 N

The torque developed by the impeller is given as

$$T = Fr \quad \text{----- (6)}$$

Where; r = radius of impeller, 0.18 m, F = shelling force, 40.78 N T = 7.34 Nm

The minimum power requirement is given as P = Tω (Khurmi and Gupta, 2006) ----- (7)

Where:

T = torque developed, 7.34 Nm ω = angular velocity, 171.39 rad/s, P = 1.26 KW (1.69 hp)

Based on this minimum power requirement, 2 hp single phase motor was selected. According to Ismail et al. (2015), the shaft will be subjected to torsional, bending stress or both and the shaft diameter obtained using equation 8.

$$d = \left[ \frac{16}{\pi \sigma_b} \left( (K_m M_b) + \left( \sqrt{(K_m M_b)^2 + (K_t M_t)^2} \right) \right) \right]^{1/3} \quad \text{----- (8)}$$

Where:

K<sub>m</sub>, K<sub>t</sub> = shock and fatigue factor for bending and torsional moments (1.5 and 1.0)

M<sub>b</sub> = maximum bending moment on shaft (Nm) M<sub>t</sub> = maximum torsional moment on shaft (Nm) σ<sub>b</sub> = maximum permissible working stress for steel (55 MPa)

The load acting on the shaft comprises of weight of impeller, pulley and shaft aligning ball bearings.

$$M_b = \frac{W * L}{4} \quad \text{----- (9)}$$

Where:

W = total vertical load acting on shaft L = length of shaft

$$\text{But } W = T_1 + T_2 \quad \text{----- (10)}$$

Where: T<sub>1</sub> = tension on tight side of belt, T<sub>2</sub> = tension on slack side of belt

The mechanical power transmitted by the belt is a product of force and velocity.

$$P = v (T_1 - T_2) \quad \text{----- (11)}$$

$$T_1 - T_2 = \frac{P}{v}$$

$$T_1 - T_2 = 40.84 \text{ N} \quad \text{----- (12)}$$

Also, the ratio of tensions,

$$\frac{T_1}{T_2} = e^{\mu\theta} \quad \text{----- (13)}$$

Where:  $\mu$  = coefficient of friction between belt and drive pulley,  $0.3$   $\theta = \pi$  e of wrap,  $180^\circ$  ( $\pi$  radians)

$$2.310 \ln \frac{T_1}{T_2} = 0.9426 \quad \text{----- (14)}$$

$$T_1 = 2.57 T_2 \quad \text{----- (15)}$$

Thus,  $T_2 = 26.01 \text{ N}$ ,  $T_1 = 66.85 \text{ N}$ ,  $W = 92.86 \text{ N}$  and  $M_b = 11.61 \text{ Nm}$

Using a shaft material of cold drawn carbon steel and maximum permissible working stress of  $55 \text{ MPa}$ , diameter of shaft is calculated thus.

$$d = \left[ \frac{16}{3.142 \cdot 55 \cdot 10^6} \left( (15 \cdot 11.61) + \left( \sqrt{(15 \cdot 11.61)^2 + (1.0 \cdot 734)^2} \right) \right) \right]^{1/3}$$

Value obtained for  $d$ , was  $14.98 \text{ mm}$ , thus a  $20 \text{ mm}$  shaft was selected.

### III. RESULT AND DISCUSSION

Table 1. Performance data for Bambara groundnut sheller

Shelling operation Sequence	Number of nuts	Wholesome nuts	shelled nuts	Partially shelled nuts	Unshelled nuts	Time taken
1	100	65	6	15	4	
2	100	66	10	9	5	
3	100	60	10	8	5	
4	100	68	7	9	6	
5	100	70	6	4	5	
Average	100	65.8	7.8	9	5	

Table 1 shows the results of the performance test analysis. The performance characteristics of the machine were evaluated as follows: cracking efficiency (83.2%); seed breakings (17.4%); partially shelled pods (7.8%); unshelled pods (9%) and a machine capacity of 75000 seeds/hr. The results indicated that the performance of the machine was dependent on the speed of the impeller and most importantly the moisture content of the seeds. The speed of rotation of the impeller was set at 1636 rpm and at this speed the cracking efficiency was 8%. The moisture content at the time of testing was 6% (wb). It was observed that about 12% of the seeds were cracked. The sun drying of the bambara groundnuts before testing the machine was necessary in order to improve the shelling ability of the seeds. The shelling machine was seen to be

very consistent in the quality of the shelled bambara groundnut seeds.

### IV. CONCLUSION

A centrifugal impact machine for shelling bambara groundnut pod was designed constructed and evaluated. It could be concluded from the results of the investigation. The shelling efficiency from the machine test was 83.2% at a moisture content of 5 - 7% w.b. and the percentages of partially shelled, unshelled and cracked seeds were moderately low. Therefore, the mechanisation for bambara processing is feasible as it will help to curb the drudgery of manual cracking. In conclusion, a centrifugal impartation method can be used effectively to shell bambara nuts.



## REFERENCES

- [1]. Adigun, Y. J. and Oje, K. (1993). Thevetia fruit processing: energy requirement for cracking the nut. Proceedings of the Nigeria Society of Agricultural Engineers 15: 128-129.
- [2]. Ajayi, F. A. and Lale, N. E. S. (2001). Susceptibility of unprotected seeds and seeds of local bambara groundnut cultivars protected with insecticidal essential oils to infestation by *Callosobruchus maculatus* (F.) (Coleoptera: Bruchidae). Journal of Stored Products Research 37: 47-62.
- [3]. Akani, A. O., Ohanwe, C. N. and Omoniyi, I. O. (2000). Determination of optimum impact for decortication of bambara groundnut. Proceedings of the Nigeria Society of Agricultural Engineers 22: 87-89.
- [4]. Alonge, A. F. and Idung, M. (2015). Development of bush mango (*Irvingia gabonensis*) nutcracker. Agricultural Engineering International: CIGR Journal 17(2): 191-199.
- [5]. Atiku, A. A. (2000). Bambara groundnut processing and storage practices in North Eastern Nigeria. Maiduguri, Nigeria: University of Maiduguri, Postgraduate seminar, Agricultural and Environmental Resources Engineering Department.
- [6]. Baryeh, E. A. 2001. Physical properties of bambara groundnuts. Journal of Food Engineering 47: 321-326.
- [7]. Babatunde, O. O. and Okoli, J. O. (1988). Investigating the effect of nut sizes on the speed needed for cracking palm nuts in centrifugal nut crackers. Nigerian Journal of Palms and Oil Seeds 9: 94-98.
- [8]. Brough, S. H., Azam-Ali, S. N. and Taylor, A. J. (1993). The potential of bambara groundnut (*Vigna subterranean*) in vegetable milk production and basic protein functionality systems. Food Chemistry 47: 277-283.
- [9]. Etoamaihe, U. J. and Ndubueze, K. C. (2010). Development and performance evaluation of a dehulling machine for African breadfruit (*Treculia Africana*). Journal of Engineering and Applied Sciences 5(4): 312-315.
- [10]. Ezue, M. I. (1977). Cultivation and utilization of minor food legume in Nigeria. Tropical Grain Legumes Bulletin 10: 7-12.
- [11]. Ismail, S. O., Ojolo, S. J., Orisaleye, J. I., Adediran, A. A. and Fajuyitan, O. O. (2015). Design and development of an improved palm kernel shelling and sorting machine. European International Journal of Science and Technology 4(20): 225-240.
- [12]. Kay, D. E. (1979). Food legume crops and production. Digest 3. London: Tropical Products Institutes.
- [13]. Khurmi, R. S. and Gupta, J. K. (2006). A textbook of machine design. New Delhi: S. Chand.
- [14]. National Research Council. (2006). Lost crops of Africa: vol. II: vegetables. Washington DC: National Academic Press.
- [15]. Obiakor, S.I. and Babatunde, O. O. (1999). Development and testing of the NCAM centrifugal palm nut cracker. Report of the Nigerian Agricultural Mechanization Research. National Centre for Agricultural Mechanisation, Ilorin.
- [16]. Oje, K., Adigun, Y. J. and Alonge, A. F. (1997). Cracking energy for Shea nuts in centrifugal crackers. Nigerian Journal of Pure and Applied Sciences 12: 550-555.
- [17]. Olakanmi, E. O. 2004. Development and performance testing of palm kernel nut cracker. Compendium Engineering Monographs 13: 27-30.
- [18]. Oluwole, F. A., Abdulrahim, A. T. and Olarere, R. K. (2007). Evaluation of some centrifugal impaction devices for shelling bambara groundnut. Agricultural Engineering International: The CIGR Journal 9: PM 07 007.
- [19]. Oluwole, F. A., Aviara, N. A. and Haque, M. A. (2004). Development and performance tests of a sheanut cracker. Journal of Food Engineering 65: 117-123.
- [20]. Tanimu, B. and Aliyu, L. (1995). Northern Nigeria. In Heller, J., Begemann, F. and Mushonga, J. (Eds). Proceedings of the Workshop on Conservation and Improvement of Bambara Groundnut (*Vigna subterranea* (L.) Verdc.), p. 45. Harare: Department of Research and Specialist Services.