

A Multiband Circular Patch Antenna with Rhombus slot for 4G, 5G, Wi-Max Applications

Dr. Milind S. Narlawar, ArchitM. Jugade, Parikshit D. Deshpande

Department of Electronics & Telecommunication Yeshwantrao Chavan College of Engineering Nagpur, India
Department of Electronics and Telecommunication Yeshwantrao Chavan College of Engineering Nagpur, India
Department of Electronics and Telecommunication Yeshwantrao Chavan College of Engineering Nagpur, India

Submitted: 01-05-2021

Revised: 09-05-2021

Accepted: 10-05-2021

ABSTRACT—A circular rhombus slot antenna with microstrip feed line is proposed in this paper. A circular shaped patch has a rhombus shape slot in it, then attached to a microstrip feed line. The s-parameter, gain, linear polarization, VSWR and radiation pattern are calculated at various operating frequencies. A multiband frequency range of 2.23 GHz to 2.27 GHz, 3.9 GHz to 4 GHz, 5.37 GHz to 5.47 GHz, 6.10 GHz to 6.19 GHz, 6.56 GHz to 6.75 GHz and 7.17 GHz to 7.34 GHz is achieved with resonant frequency of 2.251 GHz and 3.952 GHz. Maximum gain of around 1.24 dB and directivity of 6.67dBi is achieved. Various parameters mainly consisting of gain and surface current are studied at these frequencies. This design is useful in different types of applications like 4G, 5G, Wi-Fi, Wi-MAX, WLAN.

Keywords—rhombus slot; circular; linear polarization; multiband.

I. INTRODUCTION

A circular shaped rhombus slot antenna is proposed using FR-4 substrate [1]. FR₄ is an easily available dielectric material which has better mechanical properties. The proposed antenna is not at all heavy and have very low production cost as it is simple in design. The dielectric constant of FR₄ is 4.3 which is quite high so, it is best suitable for various microwave applications.

Next to the rectangular patch the circular patch configuration comes (as shown in figure 1) having various applications as a single element and also arrays. The TM_z modes which primarily takes place in circular patch antenna where substrate height is small are called as TM_z where z is perpendicular to the patch surface [5]. Only one degree of freedom is there to control in the circular patch. Because of this the absolute value of resonant frequency gets changed. Moreover, Monopolar patch antenna is studied widely [2]–[3] as its monopole radiation patterns with low-profile

structure. Han demonstrated a reconfigurable patch antenna in [4] to cope up with the demand of modern mobile communication services [6]–[7].

II. PROPOSED DESIGN

A. Antenna Design

In Fig.1a, front view of the proposed circular patch rhombus slot antenna is portrayed. Substrate used is FR4 lossy with 1.6 mm thickness. As from the front view design, circular shaped patch has a rhombus shape slot in it, then attached to a microstrip feed line. Then a microstrip feed line with an edge feeding is used which is provided from the bottom end and have a length of about 20 mm and is 2.4 mm in width.

The substrate is 60mm × 60mm dimension and has dielectric constant of 4.3. In Fig.1b, ground plane of antenna is portrayed.

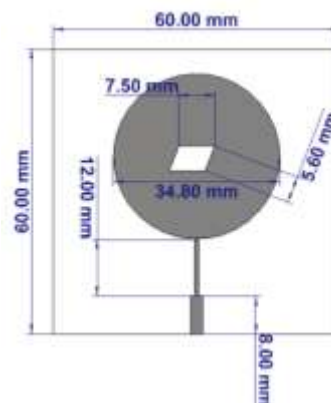

Fig.1a. Front view of proposed antenna.

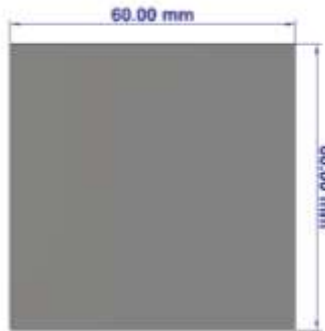

Fig.1b. Back view of proposed antenna. The dimension table of the proposed antenna is shown below.

TABLE I
 DIMENSIONS OF THE CIRCULAR ANTENNA
 (UNIT: mm)

Parameters	Measurement
Substrate thickness (t)	1.6
Substrate length (l)	60
Substrate width (w)	60
Ground width (w ₁)	60
Ground length (l ₁)	60
Ground thickness (t ₁)	0.035
rhombus slot length (l ₂)	5.6
rhombusslot width(w ₂)	7.5
feed length(f ₁)	20
feed width(f)	2.4

III. SIMULATION RESULTS & DISCUSSIONS

The proposed antenna has dimension of 60×60×1.6 mm and is designed using Computer Simulation Technology (CST) 2017 tool. S-parameters, surface current, gain and radiation patterns measurements are shown.

A. Discussion on results

In Fig.3a, S₁₁ parameter results are depicted which shows a multiband frequency range of 2.23 GHz to 2.27 GHz, 3.9 GHz to 4 GHz, 5.37 GHz to 5.47 GHz, 6.10 GHz to 6.19 GHz, 6.56 GHz to 6.75 GHz and 7.17 GHz to 7.34 GHz is achieved with resonant frequency of 2.251 GHz and 3.952 GHz.

So, from the S₁₁ results we can see that resonant frequency of 3.952 GHz has return loss of -33.43dBi. Return loss is nothing but the measure of how well the lines or devices are matched around the antenna structure [8]. Moreover, the frequency has in depth isolation and return loss. The efficiency is about 90% overall.

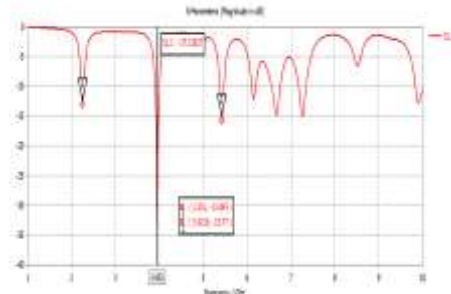

Fig.3a. S-parameters results.

Then, on resonance of 3.952 GHz a VSWR of 1.02 is also achieved depicted in Fig.3b. According to maximum power transfer theorem value of VSWR should not exceed 2 and ideally it has value of 1.

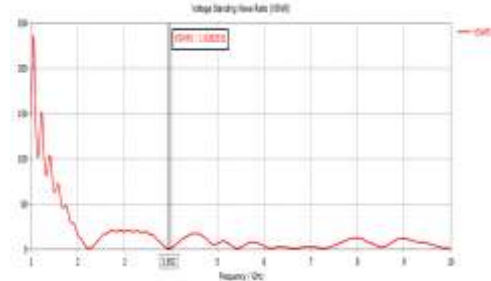

Fig.3b. VSWR at 3.952 GHz frequency.

The radiation pattern are shown in Fig.3c for 2.251 GHz frequency at constant theta and constant phi.

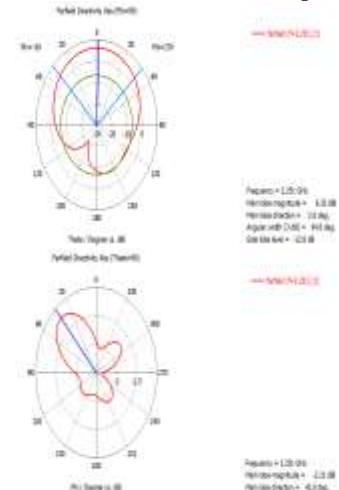

Fig.3c. Radiation pattern at 2.251 GHz.

The surface current at the resonance frequency of 2.251 GHz is shown in the Fig.3d. The

density of surface current is more at the sides of feed line and decreases a little at the bottom end of octagon. Maximum is around 97.7 A/m.



Fig.3.d. Surface current at 2.251 GHz frequency.

The directivity at 2.251 GHz frequency of about 6.33 dBi and gain of about 1.24 dB is achieved, which is shown in Fig.3e and Fig.4. The surface area covered by the gain can be clearly seen and it shows that most of the part which was necessary for propagation in one direction is covered.

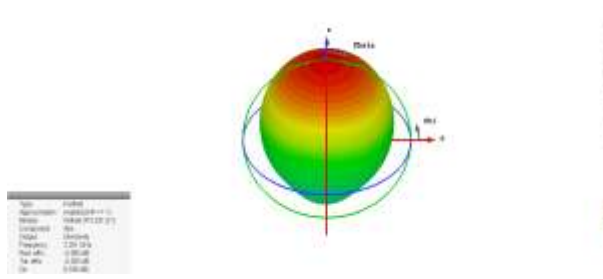

Fig.3.e. Directivity at 2.251 GHz frequency.

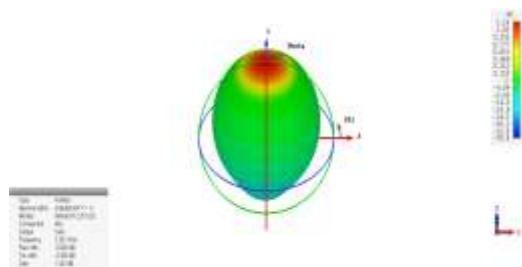

Fig.4. Gain at 2.251 GHz frequency.

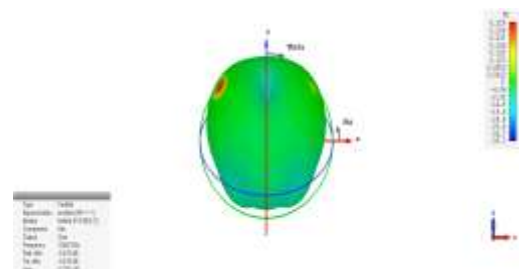

Fig.5. Gain at 3.952 GHz frequency.

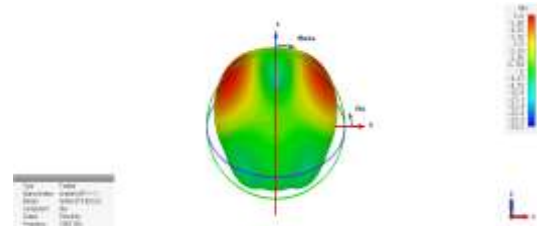

Fig.5.1. Directivity at 3.952 GHz frequency.

At 3.925 GHz frequency, gain is quite low but directivity is high, which is around 5.8 dBi. Similarly, at 5.4 GHz, the directivity is around 6.67 dBi as shown in the Fig.5.3.

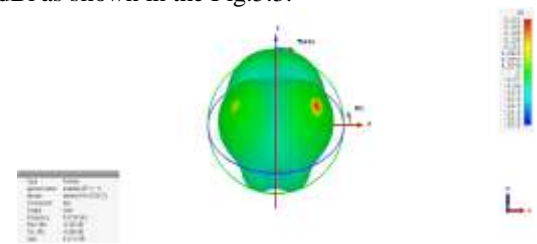

Fig.5.2 Gain at 5.4 GHz frequency.

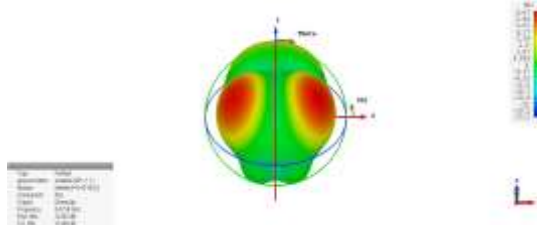

Fig.5.3. Directivity at 5.4 GHz frequency.

IV. CONCLUSION

We can conclude that the frequency range of the proposed design is from 2.23 GHz to 2.27 GHz, 3.9 GHz to 4 GHz, 5.37 GHz to 5.47 GHz, 6.10 GHz to 6.19 GHz, 6.56 GHz to 6.75 GHz and 7.17 GHz to 7.34 GHz is achieved with resonant frequency of 2.251 GHz and 3.952 GHz. Due to rhombus slot implementation isolation is achieved as the current get trapped around. The design made is acceptable for the applications like WLAN, PAN, 4G, 5G, Wi-MAX and other.

Moreover, this multiband can be varied if slot and ground dimensions are changed. The band range is mostly dependent on slot dimensions and other parameters like feed line position, shape of patch. This antenna design is simple, compact, easy to design and implement & practically efficient too.

REFERENCES

- [1] "Design and Analysis of Circular Microstrip Antenna at 5.8 GHz with Fr-4 Substrate," International Journal of Advanced Research in Electrical, Electronics and

- Instrumentation Engineering Vol. 5, Special Issue 4, March 2016.
- [2] L. Economou and R. J. Langley, "Patch antenna equivalent to simple monopole," *Electron. Lett.*, vol. 33, no. 9, pp. 727–728, Apr. 1997.
- [3] J. Liu, Q. Xue, H. Wong, H. Lai, and Y. Long, "Design and analysis of a low-profile and broadband microstrip monopolar patch antenna," *IEEE Trans. Antennas Propag.*, vol. 61, no. 1, pp. 11–18, 2013.
- [4] T. Y. Han and C. T. Huang, "Reconfigurable monopolar patch antenna," *Electron. Lett.*, vol. 46, no. 3, pp. 199–200, Feb. 2010.
- [5] Panda, R.A., Mishra, D. Efficient Design of Bi-circular Patch Antenna for 5G Communication with Mathematical Calculations for Resonant Frequencies. *Wireless Pers Commun* 112, 717–727 (2020). <https://doi.org/10.1007/s11277-020-07069-9>.
- [6] M.S.Narlawar, S.L.Badjate, Shital Bramhe, "Reconfigurable Compact Circular Monopole Antenna with Defected Patch Structure for Cognitive Radio Application," *International Journal of Research in computer and Communication Technology*, Vol 2, Issue 12, December-2013.
- [7] A. Chinchole and S. Khade, "A Wideband Slot Antenna, with Simple Structure," 2020 International Conference on Emerging Trends in Information Technology and Engineering (ic-ETITE), Vellore, India, 2020, pp. 1-5, doi: 10.1109/ic-ETITE47903.2020.338.
- [8] S. S. Khade, Suvarna Talatule, S. L. Badjate,"Compact Planar Directive YagiAntenna for WLAN Application", *International Journal of Electrical, Electronics and Data Communication*, Vol. 1, Issue. 2, April-2013.